



CONTECH[®]
ENGINEERED SOLUTIONS
A QUIKRETE[®] COMPANY

CHS[®] Solution

CONTECH[®]
PIPE SOLUTIONS

CHS[®] (Culvert Headwall System) Solution

CHS[®] is composed of a corrugated metal pipe (CMP) culvert, prefabricated flat panel headwall and metric sheeting wingwalls to create a single or multi-barrel culvert system for all types and sizes. Designing with steel headwalls can save thousands of dollars versus conventional concrete headwalls.

MEETING THE TEST OF TIME

Contech has over 100 years of experience manufacturing corrugated metal pipe (CMP) for culverts and other drainage structures.

PROTECTION

Steel headwalls reduce the potential for scour and the undermining of a culvert during flow events, including a major storm for all types of basins.

EFFICIENT INLET FLOW DESIGN

Steel headwalls can more efficiently direct flows into culvert, decreasing entrance losses when compared to other entrance conditions.

DURABILITY

Steel headwalls are available in hot-dip galvanized (HDG) heavy gage steel. HDG headwalls are compatible with galvanized steel, aluminized steel, and polymer coated steel pipe culverts.

LIMITED RIGHT-OF-WAY

Headwalls help reduce the length of the culvert, allowing for improved design in limited right-of-way applications

PROJECT COST & TIME SAVINGS

CHS[®] provides immediate material savings and construction savings. Crane rental is typically not required when installing steel headwalls versus heavy concrete sections. CHS[®] allows for installation in standing water. Factory made pre-fabricated steel headwalls can save weeks of installation time versus poured in place concrete headwalls.



CHS[®] Standard Structural Design Options

Headwalls are available for round pipe up to 120" diameter and pipe arch sizes up to 120" equivalent. Headwalls are available for round and pipe arch shapes. Limited options including square ends or skewed CSP up to 30 degrees for 54" round and pipe arch shape or up to 20 degrees for 60" and above. Wing wall options include parallel to roadway, 30 or 45 degree Metric Sheeting wingwalls with 3, 6, or 9 Sheeting panels. Wingwalls are structurally pre-designed and include necessary face walers and dead man tie backs.

Contech can assist you in the design or provide a stamped and sealed design for highway loads on the headwall.

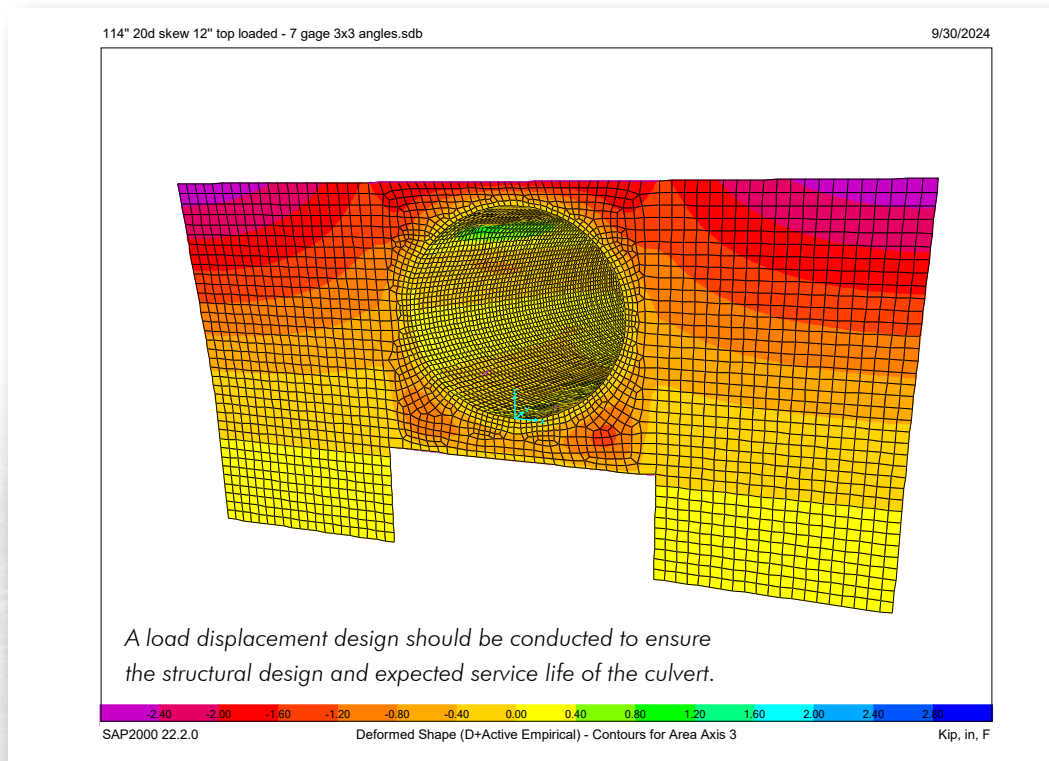

STRONG | DURABLE | COST-EFFECTIVE | EASY TO INSTALL



CHS® Standard Size for Round

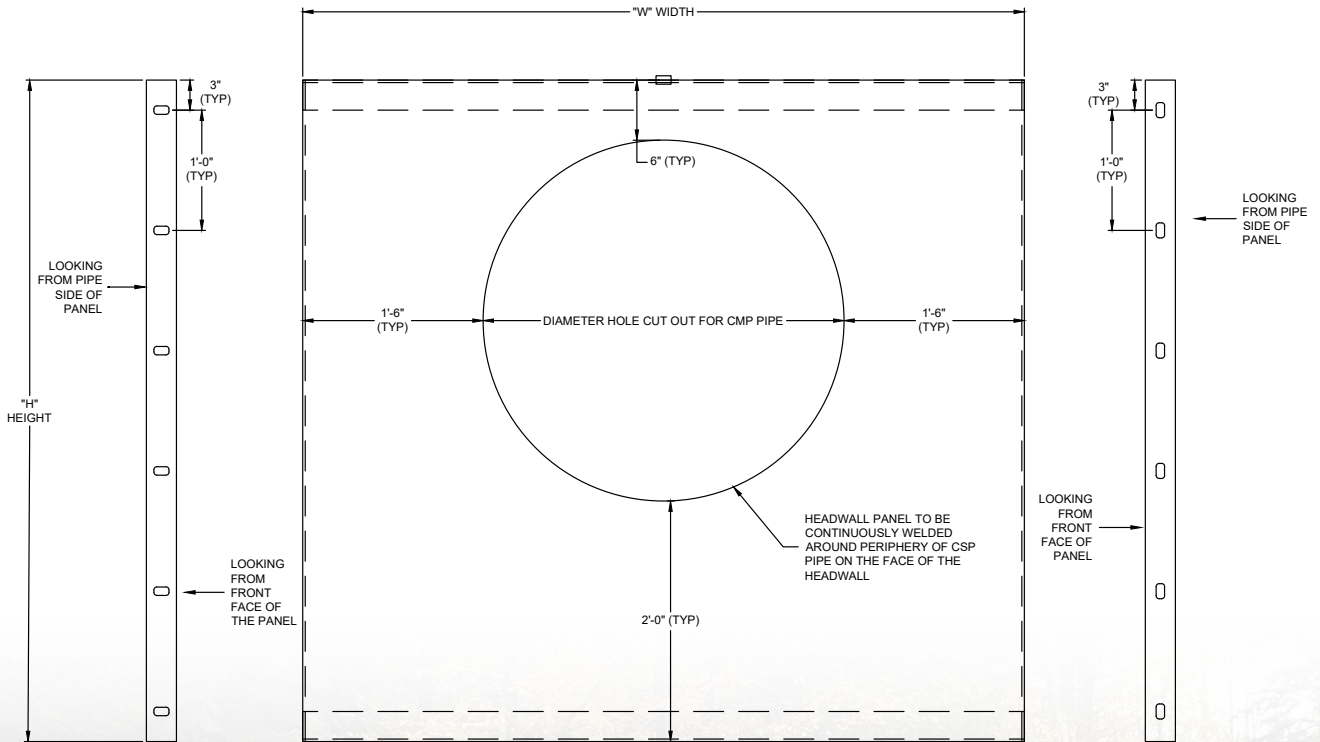

LEFT SIDE VIEW
SLOT PATTERN SAME FOR EACH LEFT SIDE OF A PANEL

ELEVATION VIEW
LOOKING FROM THE FRONT FACE OF THE PANEL

RIGHT SIDE VIEW
SLOT PATTERN SAME FOR EACH RIGHT SIDE OF A PANEL

ROUND PIPE HEADWALL			
Diameter (inches)	"W" Width (ft-in)	"H" Height (ft-in)	Finish
24	5-0	4-6	Hot-Dip Galvanized
30	5-6	5-0	Hot-Dip Galvanized
36	6-0	5-6	Hot-Dip Galvanized
42	6-6	6-0	Hot-Dip Galvanized
48	7-0	6-6	Hot-Dip Galvanized
54	7-6	7-0	Hot-Dip Galvanized
60	8-0	7-6	Hot-Dip Galvanized
66	8-6	8-0	Hot-Dip Galvanized
72	9-0	8-6	Hot-Dip Galvanized
78	9-6	9-0	Hot-Dip Galvanized
84	10-0	9-6	Hot-Dip Galvanized
90	10-6	10-0	Hot-Dip Galvanized
96	11-0	10-6	Hot-Dip Galvanized
102	11-6	11-0	Hot-Dip Galvanized
108	12-0	11-6	Hot-Dip Galvanized
114	12-6	12-0	Hot-Dip Galvanized
120	13-0	12-6	Hot-Dip Galvanized

Headwalls from non-corrugated flat metal plate.

CHS® Standard Size for Pipe-Arch

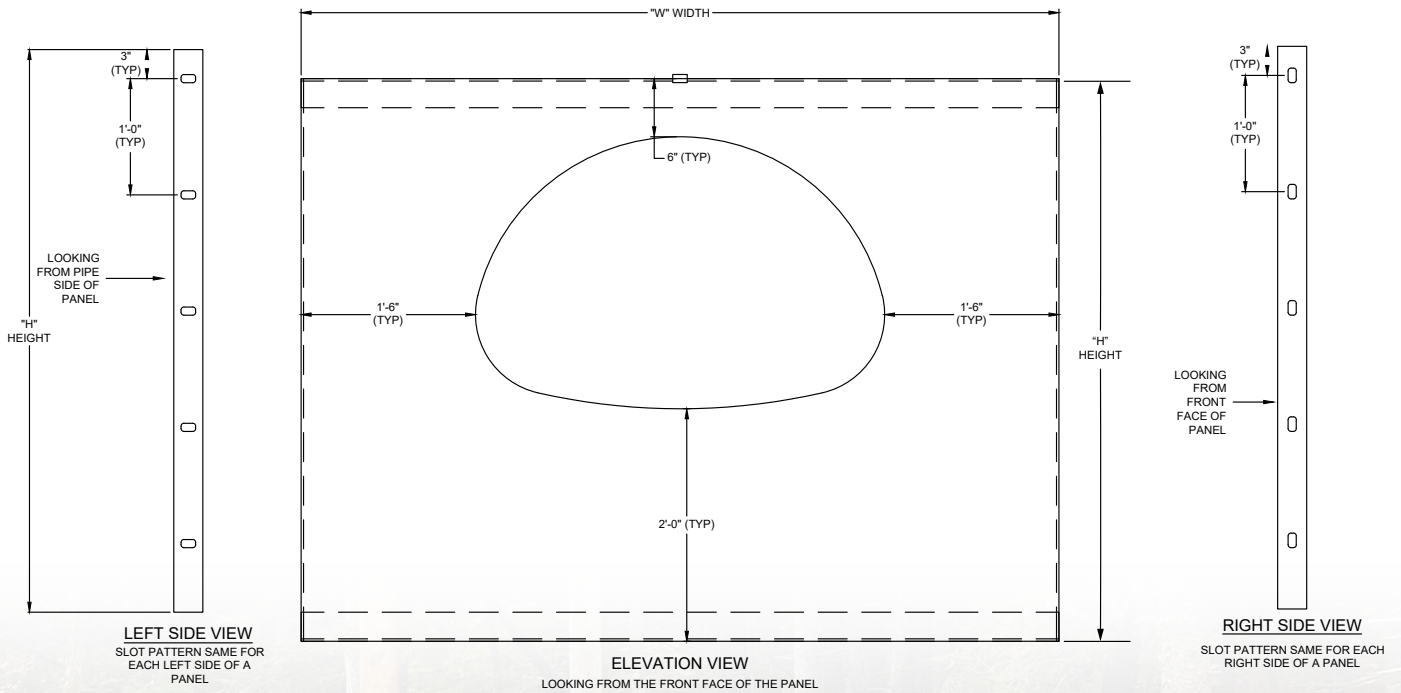

ARCH PIPE HEADWALL			
Diameter (inches)	"W" Width (ft-in)	"H" Height (ft-in)	Finish
24 (28 x 20)	5-4	4-2	Hot-Dip Galvanized
30 (35 x 24)	5-11	4-6	Hot-Dip Galvanized
36 (42 x 29)	6-6	4-11	Hot-Dip Galvanized
42 (49 x 33)	7-1	5-3	Hot-Dip Galvanized
48 (57 x 38)	7-9	5-8	Hot-Dip Galvanized
54 (64 x 43)	8-4	6-1	Hot-Dip Galvanized
60 (66 x 51)	8-6	6-9	Hot-Dip Galvanized
66 (73 x 55)	9-1	7-1	Hot-Dip Galvanized
72 (81 x 59)	9-9	7-5	Hot-Dip Galvanized
78 (87 x 63)	10-3	7-9	Hot-Dip Galvanized
84 (95 x 67)	10-11	8-1	Hot-Dip Galvanized
90 (103 x 71)	11-7	8-5	Hot-Dip Galvanized
96 (112 x 75)	12-3	8-9	Hot-Dip Galvanized
102 (117x79)	12-8	9-1	Hot-Dip Galvanized
108 (128x83)	13-3	9-11	Hot-Dip Galvanized
114 (137x87)	13-11	10-4	Hot-Dip Galvanized
120 (142x91)	14-7	10-8	Hot-Dip Galvanized
Headwalls from non-corrugated flat metal plate.			

HYDRAULIC FLOW CONDITIONS

Conventional culverts are considered round pipes and pipe-arches with uniform barrel cross-section throughout. There are six major types of culvert flow governed by one of two conditions, inlet control or outlet control.

Inlet Control – Under inlet control, the cross-sectional area of the pipe, the inlet configuration (geometry), and amount of headwater (inlet ponding) are the primary factors.

Outlet Control – Under outlet control there are additional considerations including tail water conditions, slope and culvert length.

ENTRANCE LOSS COEFFICIENTS FOR CMP (Round and Pipe Arch)	
Inlet End of Culvert	Coefficient (k_e)
Project from fill (no headwall)	0.9
Mitered (beveled) to conform to fill slope	0.7
Metal End Section conforming to fill slope	0.5
Headwall with square edge	0.5
Headwall with rounded edge	0.2
Beveled Ring	0.25

HYDRAULICS OF CULVERT IN INLET CONTROL

Inlet control means the culvert's discharge capacity is controlled at the entrance of the pipe. The three factors that govern discharge capacity are headwater depth, cross-sectional area of the pipe, and entrance conditions. (The pipe roughness, pipe length, and outlet conditions are not factors in determining the culvert capacity of an inlet-controlled pipe.)

Details A and B to the right show unsubmerged and submerged projecting inlets. Inlet control performance is classified by these two conditions (unsubmerged flow and submerged flow). Entrance loss depends upon the geometry of the inlet and is expressed as a fraction of the velocity head. Steel Headwalls help to reduce entrance losses for Corrugated Metal Pipe and Pipe-Arch, in many cases by over 40%, resulting in a greater hydraulic capacity.

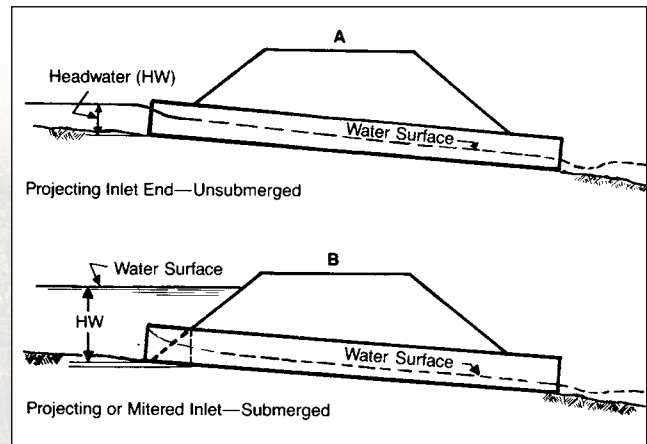

STANDARD LEAD TIMES FOR CHS®

CHS® LEAD TIMES			
Diameter (inches)	Standard Lead Times	Diameter (inches)	Standard Lead Times
24	10-12 Weeks	78	10-12 Weeks
30	10-12 Weeks	84	10-12 Weeks
36	10-12 Weeks	90	10-12 Weeks
42	10-12 Weeks	96	12-14 Weeks
48	10-12 Weeks	102	12-14 Weeks
54	10-12 Weeks	108	12-14 Weeks
60	10-12 Weeks	114	12-14 Weeks
66	10-12 Weeks	120	12-14 Weeks
72	10-12 Weeks		

CHS® Attachment Options

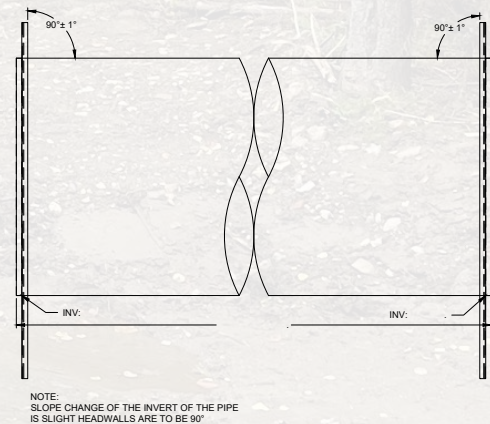
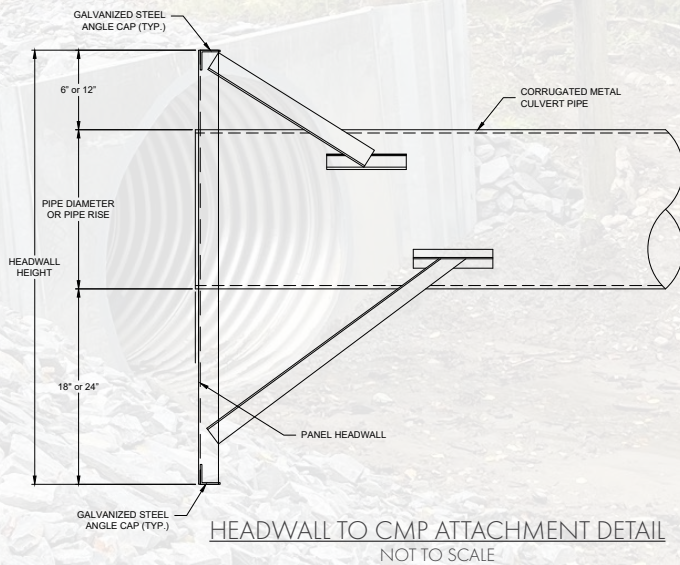
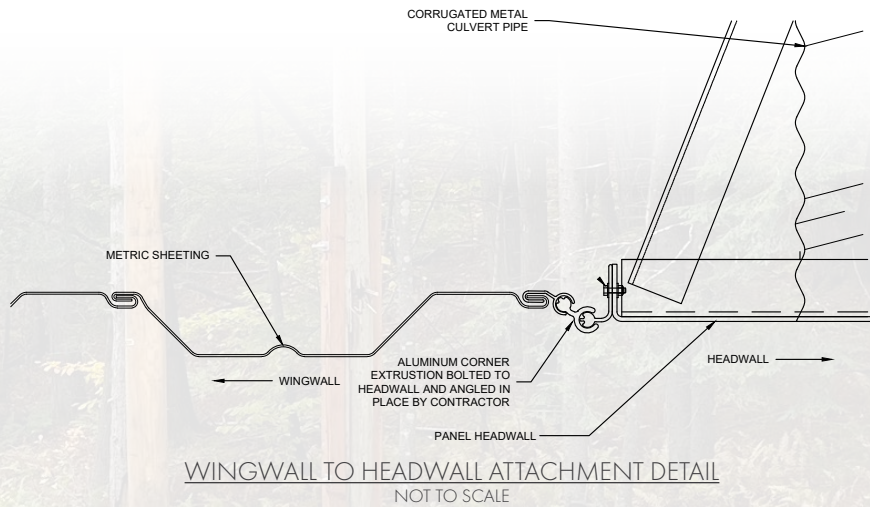
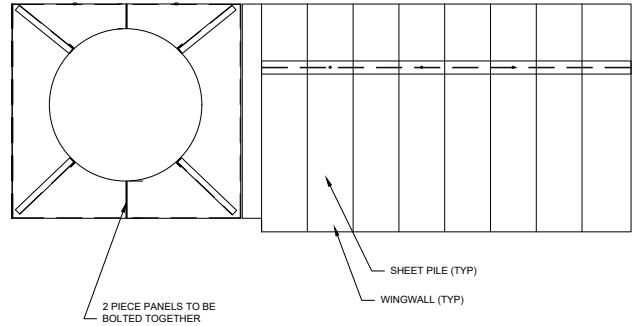
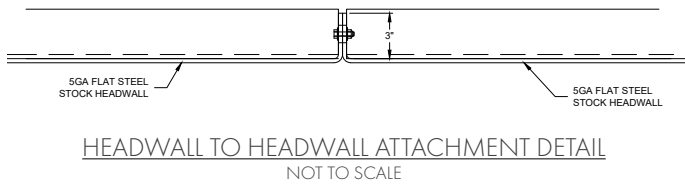

The Contech® Metric Sheeting System

THE ONLY COMPLETE SYSTEM AVAILABLE

- Contech Metric Sheeting forms the face and is the barrier between the water and soil. Long-term durability and corrosion resistance is assured by using hot-dipped galvanized.
- Deadman Anchors, sized and located according to the designer's recommendations.
- Tie Rods are hot-dip galvanized steel. Sized by the designer for the applied tensile load, they connect the deadmen and metric sheeting wall.
- Face Wales, in hot-dip galvanized steel, prevent wall bulging. Use on walls needing extra stiffness and/or require deadmen at different soil levels.
- Fasteners are hot-dip galvanized steel to resist corrosion.

Contech Metric Sheeting is installed using vibratory hammers. In less difficult soil conditions, sheeting may even be pushed into position using a backhoe bucket. Long-term durability is provided by hot-dip galvanized.

PHYSICAL PROPERTIES			
Thickness		Weight*	
Gage	Inches	lb/LF of Pile	lb/SF of Wall
7	0.1793	18	10
10	0.1345	13.4	7.4
*Weights shown are approximate.			

PHYSICAL PROPERTIES				
Gage	Section Modulus (in ³)		Moment of Inertia (in ⁴)	
	Per Section	Per Foot	Per Section	Per Foot
7	5.39	2.99	9.44	5.23
10	4.07	2.25	7.05	3.91
*Weights shown are approximate.				

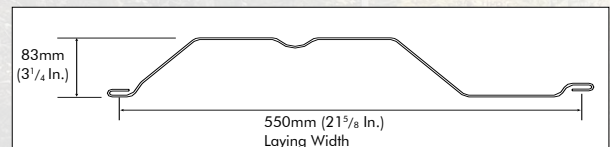

Working with Contech® Is Easy

Work with your local Contech SE to develop a cost estimate using this Culvert Headwall layout template.

CMP Headwall Fabrication Data Sheet

1 Project Information

*Project Name: *Customer Name:

*Project Number & Seq. #: *Sales Engineer:

*Order Number: *Mfg Location:

*Date: *Ship To City:

*Ship To State: *Ship To Zip Code:

Click To Lookup Zipcode; After clicking, input the City and State to see a complete list of Zip Codes.

[Export Material Data Sheet to PDF](#)

2 Headwall and Pipe Information

*Headwall Diameter:

*Pipe Corrugation:

*Grade:

*Pipe Gage:

*# of Pipe Barrells:

*Length of Pipe Barrells:

*6" or 12" Above Pipe:

*# of Bands:

*Band Type:

*Band Gage:

*Band Grade:

*Band Pieces:

*Toeplate Extensions:

3 Metric Sheeting Information

Metric Sheeting Grade:

Metric Sheeting Gage:

Length of Pieces:

of Metric Sheeting pcs Required:

of Left Starters Required:

of Right Starters Required:

4 Skew and Degree Labor Information

*Is Headwall on a Skew?:

*(If any) Skew Angle:

6 Freight Information

*FOB Plant?:

Miles From Winchester Plant to CMP Plant: Input Mfg Location!

*Miles from CMP Plant to Jobsite:

*# of Trucks:

Truck count and freight to be coordinated with the plant.

Click To Get Message; After Inputting To/From Select, "Options" and "Miles"

5 Wingwall Anchor Part Information

*Deadman Anchor:

*Aluminum Whaler:

*3/4" Anchor Rod:

INLET **OUTLET**

*Length "A" (ft) *Length "B" (ft)

Pipe Diameter

of Barrells

*Length "C" (ft) *Length "D" (ft)

*Angle "X" WW2 *Angle "W" WW3

*Angle "Y" WW1 *Angle "Z" WW4

Barrell Length

Headwall Width

Flow direction: **Single or Multi-Barrel CMP**

Labels: Left Vertical Starter ~ 6", Right Horizontal, Right Horizontal Starter ~ 10", Missing Info!

Missing Info!

Metric Sheeting Wingwall 2 Headwall Width (ft) Metric Sheeting Wingwall 1

Missing Step 1 Info!

0 Above Pipe Total Height:

0 Pipe Diameter

0 Below Pipe

Left Vertical Starter ~ 6" Headwall Info Right Horizontal Starter ~ 10"

Metric Sheeting Wingwall Headwall Width (ft) Metric Sheeting Wingwall

Length "D" (ft) Missing Step 1 Info! Length "B" (ft)

0 Above Pipe Total Height:

0 Pipe Diameter

0 Below Pipe

Outlet Facing Upstream

CHS[®] Installation

BEDDING MATERIAL

All pipes must be placed on a granular foundation. Do not install pipe on sod, frozen earth or on a bed that contains large boulders or solid rock. Foundation material must provide an allowable minimum bearing capacity designed by the engineer. When soft, unstable material is encountered at the foundation level, it must be excavated below the flow line grade and backfilled to grade with sand, gravel, or crushed stone material.

GROUP CLASSIFICATION

Group Classification	A-1-a	A-1-b	A-2-4	A-2-5
No. 10 (2.00 mm)	50 Max.	--	--	--
No. 40 (0.425 mm)	30 Max.	50 Max.	--	--
No. 100 (0.150 mm)	--	--	50 Max.	50 Max.
No. 200 (0.075 mm)	15 Max.	25 Max.	20 Max.	20 Max.
Liquid Limit	--	--	40 Max.	41 Min.
Plasticity Index	6 Max.	6 Max.	10 Max.	10 Max.

BACKFILL MATERIAL

Backfill material shall be a clean, graded, granular and porous material free from frozen material, sod, cinders or organic matter. Backfill material must be free from rocks larger than two inches. Material shall meet AASHTO M-145, table 61 - A-1, A-2-4, or A-2-5 classification.

BACKFILL PLACEMENT

The backfill should be carefully compacted under the haunches of the pipe. Continue placing the backfill equally on both sides of the pipe in 8" to 10" loose lifts thoroughly compacting each layer to a minimum of 90% Standard Proctor density (AASHTO T99) all the way to the top of grade. The backfill lifts shall be balanced between the pipes. At no time should there be more than a 2' lift differential between neighboring pipe barrels and side compaction fill area.

Backfill must be placed and fully compacted to the minimum cover level over the structure before the pipe is subjected to legal design loads. Keep heavy construction equipment that exceeds legal highway loads off the pipe. Light construction equipment on tracks such as a D-3 (or lighter) dozer may cross over the pipe when a minimum of one foot of compacted backfill is over pipe.

LOADING

Backfill must be placed and fully compacted to the minimum cover level over the structure before the pipe is subjected to design loads. When construction equipment that exceeds the legal highway loads will cross the pipe, an extra thickness of compacted fill, beyond that required for planned cover, may be required. Contact the design engineer or manufacturer's representative if there is any question as to minimum covers required for specific equipment.

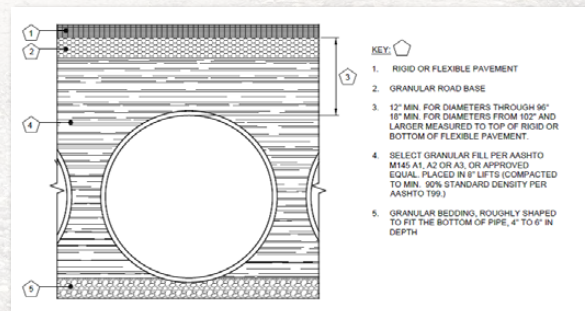

Additional End Treatments

Contech End Sections provide a practical, economical, and hydraulically superior method of finishing a variety of culvert materials. The lightweight, flexible metal construction of Contech End Sections creates an attractive, durable and erosion-preventing treatment for all sizes of culvert inlets and outlets. Headwalls can be used with corrugated metal pipe with either annular or helical corrugations, and both reinforced concrete and plastic pipes. End Sections can be salvaged when lengthening or relocating the culvert.

FEATURES & BENEFITS

- Improved hydraulics with better scour and sedimentation conditions.
- Improved finished appearance that blends well with slope design.
- Reduction of unsightly weeds and debris.
- Reduced maintenance expense from easier mowing and snow removal.



Flared End Sections



Aluminum Structural Plate with Headwall



Multiple End Sections



Step Bevel Cut End Treatment



MANUFACTURING AMERICA'S INFRASTRUCTURE™

We manufacture engineered solutions for complex civil infrastructure challenges and create lasting value for project stakeholders through unrivaled expertise, support and workmanship.

To us, it's about being a trusted partner for project owners, engineers and customers while doing meaningful work that helps build our communities.



STORMWATER SOLUTIONS



PIPE SOLUTIONS



STRUCTURE SOLUTIONS

For more information, please contact us.
www.ContechES.com | 800-338-1122

For more information, we have representatives for all 50 states.
Please call 800-338-1122 or visit www.conteches.com.

NOTHING IN THIS CATALOG SHOULD BE CONSTRUED AS A WARRANTY. APPLICATIONS SUGGESTED HEREIN ARE DESCRIBED ONLY TO HELP READERS MAKE THEIR OWN EVALUATIONS AND DECISIONS, AND ARE NEITHER GUARANTEES NOR WARRANTIES OF SUITABILITY FOR ANY APPLICATION. CONTECH MAKES NO WARRANTY WHATSOEVER, EXPRESS OR IMPLIED, RELATED TO THE APPLICATIONS, MATERIALS, COATINGS, OR PRODUCTS DISCUSSED HEREIN. ALL IMPLIED WARRANTIES OF MERCHANTABILITY AND ALL IMPLIED WARRANTIES OF FITNESS FOR ANY PARTICULAR PURPOSE ARE DISCLAIMED BY CONTECH. SEE CONTECH'S CONDITIONS OF SALE (AVAILABLE AT WWW.CONTECHES.COM/COS) FOR MORE INFORMATION.

