

HEL-COR[®] Strip-Perforated Pipe with High Structural Strength

Structural strength for ongoing efficiency

Contech[®] HEL-COR[®] Strip-Perforated Pipe has the high strength to withstand highway, railroad and other heavy loading conditions—although it is comparatively lightweight for easy installation.

It has high beam strength, which helps it bridge soft spots in the bedding. And, using a good granular, compacted backfill assures continued structural efficiency, despite frost action and the impact and vibration loads of heavy, fast-moving traffic.

Prevent groundwater hazards & maintenance costs

HEL-COR Strip-Perforated Pipe prevents freestanding water on roads and other surfaces. This eliminates traffic hazards and maintains the bearing capacity and stability of your subgrade. Introduced in 1925, HEL-COR Strip-Perforated Pipe is a practical, efficient means for eliminating unwanted water. It virtually frees you from maintenance worries by reducing the need for costly surface and subsurface repair.

HEL-COR Advantages:

Widely accepted for controlling groundwater problems, HEL-COR Strip-Perforated Corrugated Steel Pipe provides these advantages:

- 20-foot lengths, lightweight and tight, simple joints for fast, economical installation.
- High strength and stiffness for structural integrity.
- Ample infiltration capacity while preventing the entrance of solids for efficient, low-maintenance subdrainage.

Coatings and sizes

The corrugations of this durable pipe are formed helically. The pipe is made by folding over the adjacent edges of the galvanized steel, ALUMINIZED STEEL Type 2 or aluminum to form a continuous lock-seam joint. Pipe diameters range from 6-to-21 inches and are available in 18 and 16 gauge. Perforations are located in the bottom quarter points of the pipe. (See page #3.)

Economical installation

HEL-COR Strip-Perforated Pipe saves time and money. It is lightweight and has long lengths that are easy to ship and handle. Simple band couplers or sleeve joints are quickly installed to make a strong, tight conduit. No special equipment is needed, keeping job costs low.

Even greater savings are possible in backfilling because only a single filter material is required to keep trench soils out of the pipe.



Carefully conducted tests helped determine the placement, size and number of perforations needed for optimum infiltration capacity. Helical corrugations improve hydraulic efficiency.

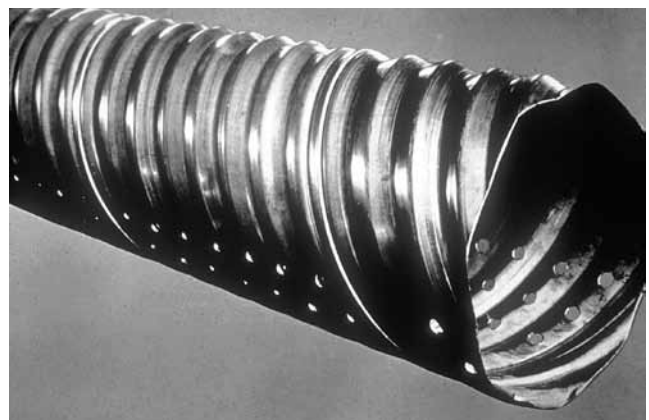

Recommended Methods of Installing CONTECH Subdrainage Systems

Thousands of installations, as well as field and laboratory tests, have provided CONTECH with the following data, which should serve as a general guide. CONTECH Sales Engineers will be glad to help you with specific or unusual installations.

Minimum slope required

Where possible, it is desirable to use a 0.2 percent minimum slope for all subdrainage lines. It is sometimes permissible to use an even flatter slope where necessary to obtain a free outlet.

Selecting pipe sizes

For normal subdrainage, the infiltration of groundwater is very slow. Therefore, approximately 500 feet of 6-inch diameter pipe may be used as an interceptor before any increase in pipe diameter is required. Where extremely pervious material is being drained or where springs are encountered, larger sizes may be required.

Placing of perforations

For general subdrainage work, CONTECH recommends that the pipe be placed with the perforations down. This helps prevent infiltration of solids that might clog the line and destroy the effectiveness of the system. Placing the perforations down also ensures a lower water table.

Where portions of the line are used as a water conductor rather than interceptor, it is permissible to place the perforations up. However, in these cases it is preferable to use nonperforated pipe if available. With either type of pipe a pervious backfill is not necessary for this portion of the line.

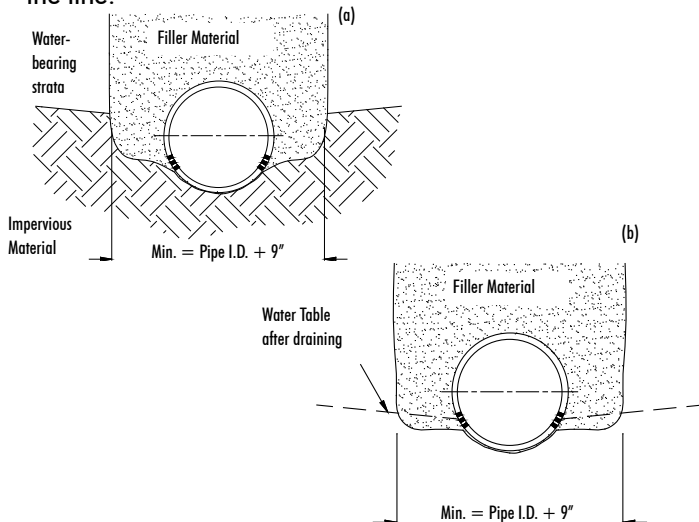

Recommended pervious backfill

When preparing the trench, it is standard practice to allow 4 inches of pervious material on each side of the pipe when a single filter material is used.

For filter purposes, AASHTO concrete sand and other less expensive types of coarse, but well graded sand, commonly available, will perform satisfactorily for perforated steel pipe in most soils. Maximum grain size is 3/8 inch. Typical analysis of this filter material is shown in Table No.1.

Table No.1 Typical size of filter material for subdrain pipe (Vicksburg tests*)	
Standard ASTM sieve	Percentage Passing
3/8 inch	100
No. 3	92
No. 4	82
No. 6	66
No. 8	53
No. 10	48
No. 16	37
No. 20	26
No. 30	11
No. 40	0

*From Technical Manual No. 183-1—U.S. Waterways Experiment Station at Vicksburg, Mississippi.

Vertical trench sidewalls are most economical for backfilling. However, in slightly unstable soils, the upper shoulder of the trench may require beveling. Highly unstable soils may require a V-shaped trench or a sheeted trench. The trench may be lined with a nonwoven geotextile for efficient, long-term filtration performance.

Special Openings

Special opening such as manholes, catchbasins or lamp holes can be supplied completely shop-fabricated.

Manholes, or risers for inspection purposes, are usually placed wherever there is a change in direction of the line. Catchbasins are used in combined drains for collecting surface water. Where aeration is desirable, catchbasins placed at the end of the line will help facilitate air circulation.

Pipe outlets

Free outlets are important and the failure of subdrains to properly function can often be attributed to plugged, damaged or improper outlets.

Outlet pipes should be protected from damage by maintenance equipment and a suitable screen used to keep out rodents whose nests could cause clogging.

If it is difficult to obtain a suitable outlet for the drainage system, it may be necessary to carry the water to a sump and then pump it out.

Standard perforations in HEL-COR Strip-Perforated Pipe

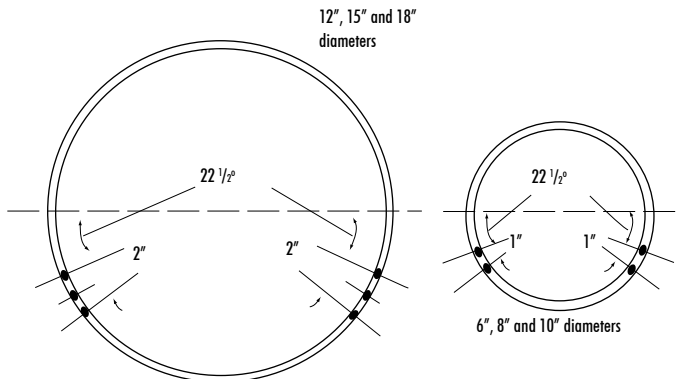

Unperforated Invert = 90° min.
 Dimensions are approximate.
 All perforations nominal $\frac{3}{8}$ " in diameter

Standard fittings for CONTECH Pipe

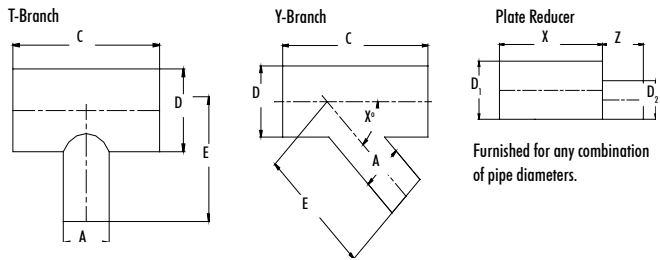

T-Branched and Crosses are furnished in any combination of sizes where A and B are equal to or less than barrel diameter D.

Y and Double Y Branches are furnished in any combination of sizes where A and B are equal to or less than the barrel diameter D. X = 45° or 60°.

Furnished for any combination of pipe diameters.

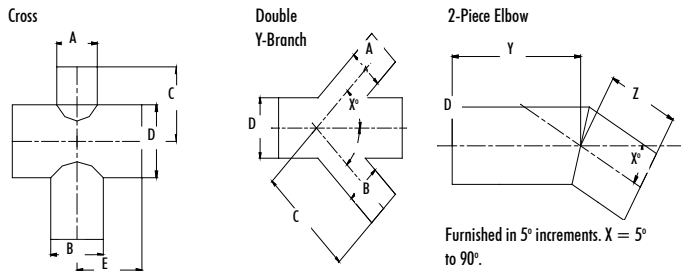

Furnished in 5° increments. X = 5° to 90°.

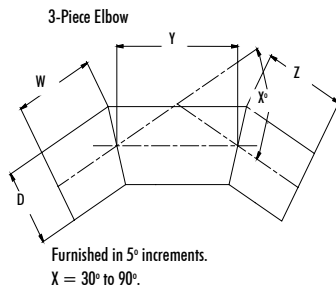

Furnished in 5° increments. X = 30° to 90°.

Spacing of laterals

Draining large, comparatively flat areas generally requires a parallel or herringbone system of drainage pipe. Table No. 2 may be used as a broad guide in laying out the system. The spacing used on highways and railroads is controlled by the location of the water-bearing strata.

All standard fittings are available for use with perforated pipe. These are supplied separately, ready for field connection with band couplers or sleeve joint construction.

Table No. 2
Approximate spacing of laterals

Soil Classes	Percent of Soil Separates			Distance Between Subdrains in feet
	Sand	Silt	Clay	
Sand	80-100	0-20	0-20	150-300
Sandy Loam	50-80	0-50	0-20	100-150
Loam	30-50	30-50	0-20	85-100
Silt Loam	0-50	50-100	0-20	75-85
Sandy Clay Loam	50-80	0-30	20-30	65-75
Clay Loam	20-50	20-50	20-30	55-65
Silty Clay Loam	0-30	50-80	20-30	45-55
Sandy Clay	50-70	0-20	30-50	40-45
Silty Clay	0-20	50-70	30-50	35-40
Clay	0-50	0-50	30-100	30-35

All fittings are furnished in the shortest lengths possible, but with sufficient length for attaching standard connecting bands. Bends up to 5 degrees can be made in one or two standard connecting bands due to their flexibility. Connecting bands are corrugated to match corrugations in the pipe and ensure strong joints.

Fully-Perforated Pipe is Available

Fully perforated metal pipe for recharge systems and other applications is also available from Contech, as well as fully perforated PVC pipe and a full line of prefabricated geocomposite subsurface drainage products. For details, call your local Contech Sales Engineer.

Specifications for Strip-Perforated Steel Pipe Underdrains

CONTECH HEL-COR Strip-Perforated Steel Pipe is available in pregalvanized steel, (HEL-COR), ALUMINIZED STEEL Type 2 (HEL-COR), steel, and aluminum (CORLIX®). It is fabricated in accordance with AASHTO Designation M 36 Type III, classes I, II and III. CONTECH Strip-Perforated Aluminum Pipe (CORLIX) is fabricated in accordance with AASHTO Designation M 196, Type III, classes I and II.

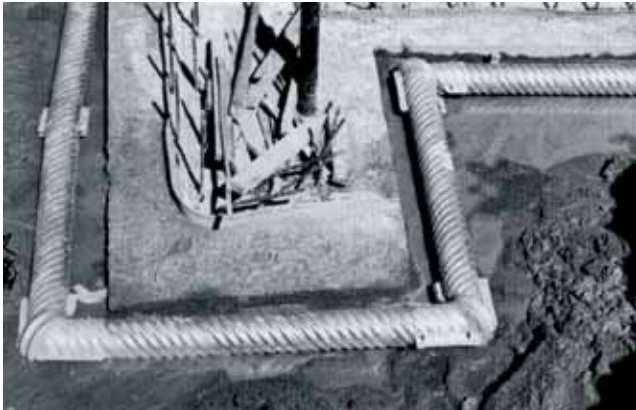

HEL-COR Strip-Perforated Pipe can eliminate groundwater problems at building foundations.

Contech Engineered Solutions provides site solutions for the civil engineering industry. Contech's portfolio includes bridges, drainage, retaining walls, sanitary sewer, stormwater, erosion control, soil stabilization and wastewater treatment products.

For more information, call one of Contech's Regional Offices located in the following cities:

Visit our web site: www.conteches.com
800.338.1122

NOTHING IN THIS CATALOG SHOULD BE CONSTRUED AS AN EXPRESSED WARRANTY OR AN IMPLIED WARRANTY OF MERCHANTABILITY OR FITNESS FOR ANY PARTICULAR PURPOSE. SEE THE CONTECH STANDARD CONDITIONS OF SALE (VIEWABLE AT WWW.CONTECHES.COM/COS) FOR MORE INFORMATION.

BRO-HCPP v.2 05/15 PDF Only

Table No. 3
Dimensions, thickness, spacing of perforations and stiffness of pipe

Nominal Internal Diameter (Inches)	Minimum No. of Rows of Perforations	Minimum Width of Non-perforated Segment (Inches)	Comparable Stiffness Levels* CSP (18 ga) (psi)	Comparable Stiffness Levels* CSP (16 ga) (psi)	Comparable Stiffness Levels* HDPE ASTM F 405 F 667 (psi)	Comparable Stiffness Levels* HDPE ASTM M 252 M 294* (psi)
6"	4	4	> 200	> 200	30	35/50
8"	4	7	> 200	> 200	30	35/50
10"	4	9	> 200	> 200	30	35/50
12"	6	9	> 200	> 200	30	50
15"	6	13	200	250	30	42
18"	6	16	125	160	30	40
21"	6	20	100	130	—	38

* Based on test data or specification minimums.

** Pipe with an inner non-corrugated wall provides 50-psi stiffness.

Table No. 4
Maximum Heights-of-Cover

Nominal Internal Pipe Diameter	AASHTO Cover Limits M36 — 18 gauge pipe*	AASHTO Cover Limits M 252 and M 294
6"	255 feet	Unspecified
8"	191 feet	Unspecified
10"	152 feet	Unspecified
12"	165 feet	11 feet
15"	131 feet	11 feet
18"	110 feet	11 feet
21"	94 feet	11 feet

*Based on sections 12 and 18 of the AASHTO Standard Specifications for Highway Bridges (the CMP pipe design specifications). Above limits reduced to compensate for wall area reduction due to perforations. 16 gauge Cover Limits are approximately 20% higher than 18 gauge. Strip-Perforated Corrugated Steel Pipe has much higher beam strength than the M 252 and M 294 plastic pipe. Higher beam strength and stiffness can be important in areas with poor bedding/foundations and/or high wheel loads.

CONTECH
ENGINEERED SOLUTIONS

©2015 Contech Engineered Solutions LLC
All rights reserved. Printed in USA.