

Rehabilitating Aging Infrastructure » Sewers, Culverts & Bridges



The New Infrastructure

When storm and sanitary sewers, culverts and bridge infrastructure reaches the end of a useful service life, the decision to excavate and replace is commonplace. Rehabilitation or relining of these storm and sanitary sewers, culverts and small bridges can be a faster and less expensive option that imparts little to no impact on traffic maintenance.

Rehabilitation — Get In, Get Out, Stay Out™

Contech® offers a variety of products and systems, combined with more than 100 years of experience, to facilitate rehabilitation of storm and sanitary sewers, culverts and bridges.

Design Considerations for Rehabilitation versus Replacement

Rehabilitating or relining a drainage or sanitary pipeline or structure requires a site-specific analysis. There is no one-size-fits-all approach. Every reline project needs to be examined closely by qualified professionals.

From an engineering perspective, the design approach must take into account the usual design parameters and must carefully evaluate the current condition of the pipe or structure and the supporting fill that surrounds it. The primary areas where an engineer should be concerned are:

- Geometric shape and condition of existing pipeline or structure (and access structure)
- Hydraulic requirements and limitations
- Optimum shape, size and materials
- Constructability
- Design service life
- Structural analysis and design
- Specification goals

Variety of Products for More Efficient Rehabilitation

	SPAN RANGE	PRODUCT	DESCRIPTION
DRAINAGE	12" – 36"	A2™ Liner Pipe	PVC corrugated pipe with smooth interior wall
	18" – 102"	ULTRA FLO®	Spiral rib aluminum, aluminized and polymer coated steel pipe
	12" – 144"	Corrugated Metal Pipe	Corrugated aluminized and polymer coated steel and aluminum alloy helical pipe
	30" – 120"	DuroMaxx®	Steel reinforced polyethylene pipe
SEWER	12" – 36"	A2™ Liner Pipe	PVC corrugated pipe with smooth interior wall
	30" – 120"	DuroMaxx®	Steel reinforced polyethylene pipe
	30" – 120" +	SPR™ PE	Spiral-wound steel reinforced PE pipe
STRUCTURES	4' – 20' +	Tunnel Liner Plate	Steel and aluminum 2- flanged liner plate
	5' – 23' +	ALSP MULTI-PLATE®	Aluminum structural plate Galvanized steel structural plate
	8'-9" – 35'-5"	ALBC	Aluminum box culvert
	19'-5" – 65'	SUPER SPAN™ SUPER-PLATE® BridgeCor®	Galvanized steel structural plate long spans Aluminum structural plate long spans Deep corrugation galvanized steel structural plate
	12' – 102'	CON/SPAN® and BEBO®	Precast concrete arches

Segmental Sliplining Process for Plastic Pipe

These include DuroMaxx[®], A2[™] Liner and -Tite[®] products. Consult your local Contech representative for more details.

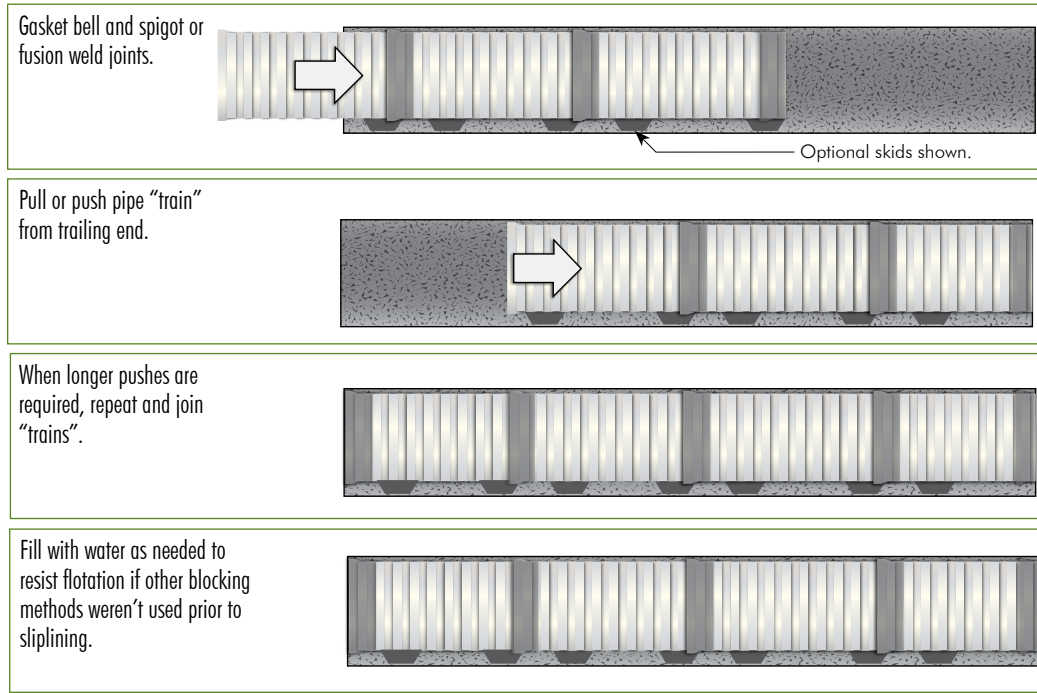

Segmental Sliplining Process for Corrugated Metal Pipe

These include HEL-COR[®], ULTRA FLO[®], CORLIX[®] and SmoothCor[™] products. Consult your local Contech representative for more details.

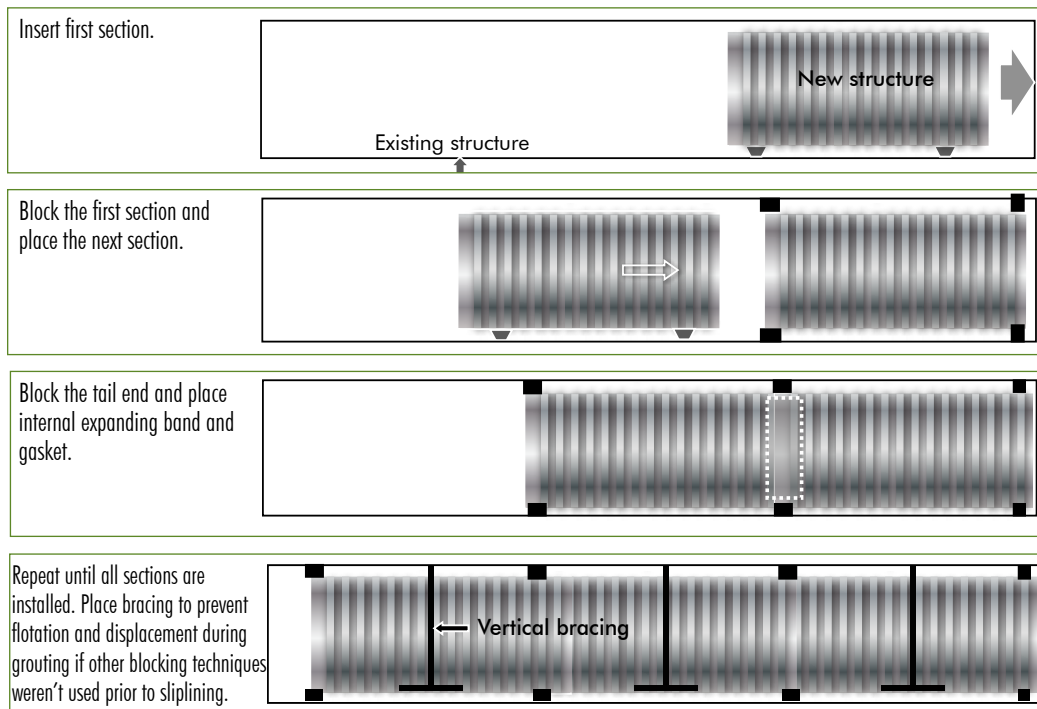

PVC — A2™ Liner Pipe

Cost-Effective Rehabilitation with Proven Trenchless Installation Methods

The increasing rate of sanitary and storm sewer deterioration requires an efficient and cost-effective rehabilitation solution. Contech A2 Liner Pipe uses proven trenchless installation methods to slipline existing sewer lines without the disruptions associated with open trenching — while increasing productivity and lowering costs.

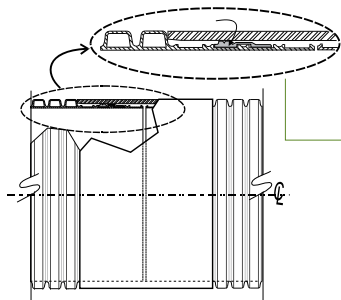

The A2 Liner Pipe has a unique STAB-JOINT coupler that fits flush with the outer wall surface for easy installation while ensuring proper load transfer across the joint during installation.



A2 Liner Pipe Increases Hydraulic Capacity

When reinforced concrete and vitrified clay pipe have offset joints, cracks, spalling or protrusions, there is greater resistance to flow, reducing hydraulic capacity. Significant hydraulic improvements are achieved when these deteriorated pipes are sliplined with A2 Liner. A Manning's "n" value of .009 can actually result in increased flow capacity and higher flow velocities for improved self-cleaning.

The Manning equation can be used to determine the flow capacities for circular pipes before and after rehabilitation:

$$\% \text{ Existing Flow} = \frac{n_{\text{existing}}}{n_{\text{A2 Liner}}} \left[\frac{D_{\text{A2 Liner}}}{D_{\text{existing}}} \right]^{8/3}$$

The hydraulic comparisons chart, below, compares the flow of existing concrete pipe after it is relined with A2 Liner Pipe, where:

- n = Manning's coefficient
- A2 Liner "n" = .009
- Existing RCP "n" = 0.015
- D = inside diameter

This analysis is based upon closed-system flow for sewers or outlet-controlled flow for culverts.

Hydraulic Comparisons		
Existing Diameter (in)	A2 Liner Diameter (in)	Percent Existing Flow*
15	12	92
18	15	103
21	18	111
24	21	117
27	24	122
36	30	103
42	36	111

* Sliplining with A2 Liner actually can **increase** the hydraulic capacity of existing RCP drainage systems.

Lightweight for Easy Handling and Installation

The lightweight design of the A2 Liner, coupled with a unique gasketed STAB-JOINT, makes joining easy. Lubricant, two chains and one or two come-alongs are usually all that is required to join sections. The light, easy-to-handle sections allow for maneuvering in tight workspaces. For more information, please contact your Contech representative.

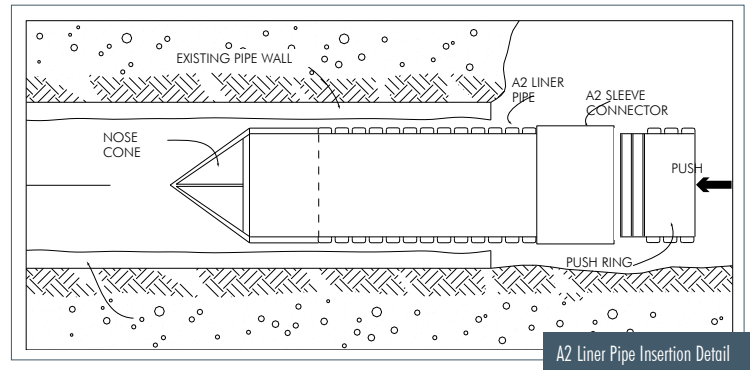

A2 Liner Pipe Dimensions

Nominal Diameter (in)	Average O.D. (in)	Average I.D. (in)
12	12.8	11.7
15	15.7	14.3
18	19.2	17.6
21	22.6	20.7
24	25.6	23.5
27	28.9	26.4
30	32.2	29.5
36	38.7	35.5



A2 Liner Pipe Jacking Loads and Pushing Distances

Pipe Diameter (in)	Safe Compressive Jacking Loads (lb)	Allowable Jacking Distance ¹ (ft)	Allowable Jacking Distance ² (ft)	Recommended Grout Pressure ³ (psi)
12	3,200	3,000	7,000	5
15	9,100	5,000	12,000	5
18	14,000	5,000	12,000	5
21	19,000	5,000	12,000	5
24	23,830	5,000	12,000	5
27	27,760	5,000	12,000	5
30	30,900	5,000	12,000	5
36	37,000	4,000	10,000	5

¹ Based on Sliding Coefficient of 0.25 | ² Based on Sliding Coefficient of 0.10

³ Contact your local Contech representative for more information about recommended grout pressure and procedures

* Includes a Factor of Safety (FS) = 3.0 for A2 Liner pipe that is installed perfectly round or a FS = 2.0 for liner pipe with 5% deflection



Steel Reinforced Polyethylene Pipe (SRPE) — DuroMaxx[®]

DuroMaxx is designed with a smooth inner wall for outstanding hydraulic capacity and provides the properties you can count on for long-term service and performance in the most demanding environments. By providing the strength of steel and the durability of plastic, DuroMaxx is an optimal reline solution in many situations.

Features

- 80 ksi steel reinforced ribbed profile walls.
- Pressure-rated polyethylene (PE) resin.
- Diameters from 30 to 120 inches.
- Standard lengths of 14 or 24 feet with bell and spigot joints. Custom lengths available.
- Watertight bell and spigot joints.
- Leak-free welded coupler (WC) joints available.



DuroMaxx Jacking Loads, Pushing Distances and Grouting Pressure

Diameter (in)	Safe Jacking Load (lbs)	Allowable Jacking Distance ¹ (ft)	Allowable Jacking Distance ² (ft)	Recommended Grout Pressure* ³ (psi)
30	2,000	426	1,064	10.3
36	2,400	407	1,017	8.5
42	2,800	415	1,037	6.7
48	3,750	487	1,218	6.4
54	4,240	470	1,175	5.6
60	4,710	439	1,098	4.9
66	5,260	370	924	5.0
72	5,810	354	886	3.9
84	6,910	362	906	4.6
96	8,010	368	921	3.1
108	9,110	365	914	2.2
120	10,220	375	938	1.6

¹ Based on Sliding Coefficient of 0.25

² Based on Sliding Coefficient of 0.10

³ Contact your local Contech representative for more information about recommended grout pressure and grout procedures

* Includes a Factor of Safety (FS) = 3.0 for DuroMaxx liner pipe that is installed perfectly round or a FS = 2.0 for liner pipe with 5% deflection.

High Performance and Low Head Joint Details — The Design Behind the Performance

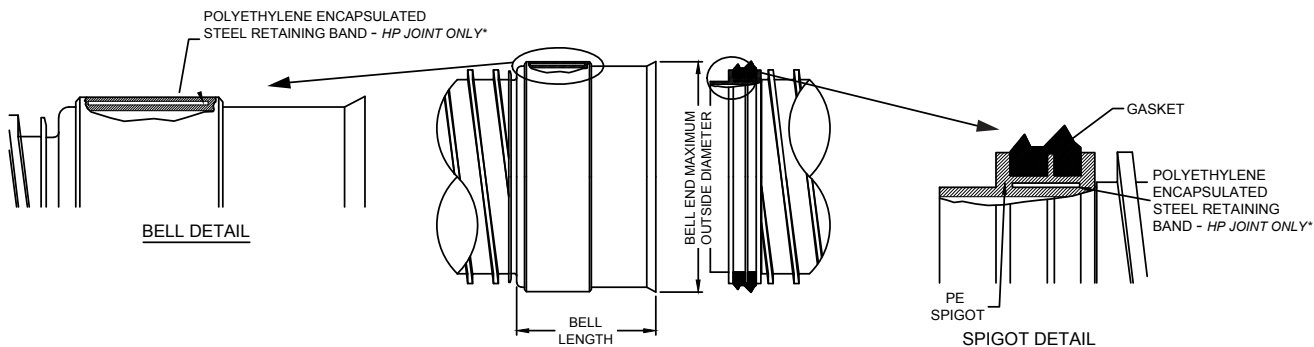

A proven trenchless installation method providing cost-effective rehabilitation and easy installation with a joint tightness on which you can depend.

- Manning's "n" of .012 restores hydraulic capacity to your sewer.
- Eliminates costly bypass operations as normal flow is maintained.
- Provides excellent durability and resistance to abrasion.
- Meets the joint tightness test requirements of ASTM D3212.

Welded Coupler Joint Detail

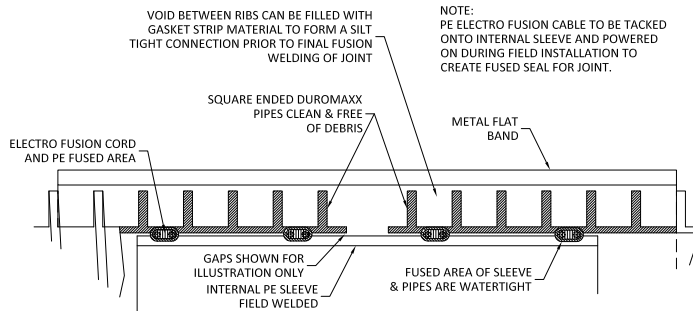

DuroMaxx Pipe Dimensions

Pipe Diameter (in)	O.D. (in)	I.D. (in)	Bell O.D. (in)	Approx. Weight (lbs/ft)
30	30.9	29.5	34.0	18.8
36	37.1	35.4	39.9	23.6
42	43.2	41.3	45.8	27.0
48	49.5	47.2	52.3	30.8
54	55.5	53.2	58.2	36.1
60	61.4	59.1	64.1	42.9
66	67.8	65.0	71.7	56.9
72	74.1	70.9	77.6	65.6
84	85.9	82.7	*	76.3
96	97.8	94.5	*	87.0
108	111.3	108	*	99.7
120	121.9	118.1	*	109.0

* A variety of joint options are available for large diameter DuroMaxx. Contact your local Contech representative for more information about available joint options and dimensions.

Grout Plug and Coupling Detail

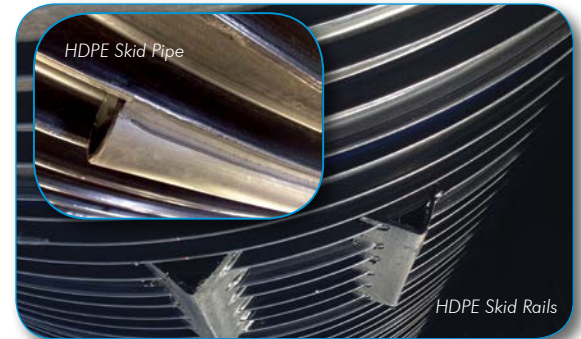
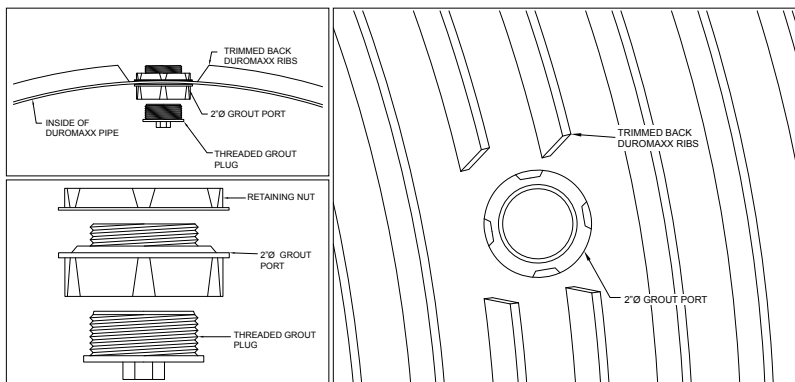

Corrugated Metal Pipe — ULTRA FLO[®] and SmoothCor[™]

Restoration of failed or deteriorating pipe can be accomplished by relining with ULTRA FLO or SmoothCor. Their low-wall profile can yield an inside diameter that approaches the original pipe, while the hydraulic capacity is improved. Contech's corrugated metal pipe is light weight and can be provided in custom lengths to meet individual site conditions, making the lining process easier.

Features

- A variety of options with estimated service life of 75+ years in recommended environments.
- A variety of premium coatings available.
- Lengths of up to 40 feet.
- Diameters from 18 to 144 inches.
- Custom lengths and diameters available.
- Smooth interior – Manning's "n" of 0.012

ULTRA FLO and SmoothCor Jacking Loads and Pushing Distances

Diameter (in)	Steel ULTRA FLO			Aluminum ULTRA FLO		
	Safe Jacking Load (lbs)	Allowable Jacking Distance ¹ (ft)	Allowable Jacking Distance ² (ft)	Safe Jacking Load (lbs)	Allowable Jacking Distance ¹ (ft)	Allowable Jacking Distance ² (ft)
18	3,220	860	2,140	1,610	640	1,610
21	3,660	820	2,030	1,830	610	1,520
24	4,070	810	2,030	2,940	650	1,630
30	4,950	790	1,970	4,380	580	1,460
36	5,090	550	1,370	7,800	670	1,690
42	4,950	330	830	8,510	650	1,630
48	4,750	280	700	9,050	600	1,500
54	5,090	270	670	9,540	560	1,400
60	5,510	260	660	10,040	540	1,350
66	10,260	440	1,110	10,110	490	1,230
72	10,180	400	1,010	10,520	460	1,160
78	10,290	380	950	11,030	450	1,120
84	14,650	500	1,260	11,480	440	1,100
90	14,840	470	1,180	---	---	---
96	14,020	420	1,050	---	---	---
102	14,420	410	1,030	---	---	---

¹ Based on Sliding Coefficient of 0.25

² Based on Sliding Coefficient of 0.10

Alignment Rod and Grout Coupling Detail

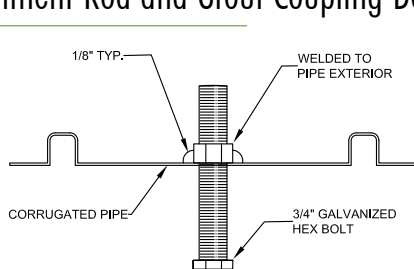

ALIGNMENT ROD DETAIL (18" LONG)
(TEMPORARY - DURING CONSTRUCTION ONLY)
N.T.S.

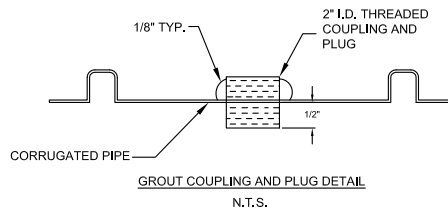

N.T.S.

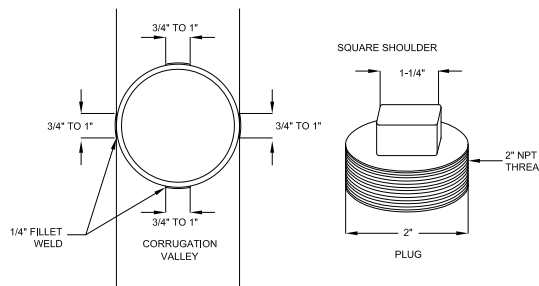

ULTRA FLO Pipe Dimensions*

Pipe Diameter (in)	Max O.D. (in)	Steel Approx. Weight (lbs/ft)	Aluminum Approx. Weight (lbs/ft)
18	20.28	15	5
21	23.28	18	6
24	26.28	20	9
30	32.28	25	15
36	38.28	37	23
42	44.28	59	26
48	50.28	67	30
54	56.32	75	34
60	62.38	83	37
66	68.44	92	41
72	74.50	100	45
78	80.56	108	49
84	86.62	116	52
90	92.68	125	---
96	98.74	133	---
102	104.80	140	---

* Based on AASHTO M36 Specifications. Custom diameters available upon request.

ULTRA FLO Grouting Pressure

Liner Diameter (in)	Steel – Max PSI Recommended* ¹		Aluminum – Max PSI Recommended* ¹	
	Round	5% Deflection	Round	5% Deflection
18	5 ²	5 ²	5 ²	5 ²
21	5 ²	5 ²	5 ²	5 ²
24	5 ²	5 ²	5 ²	5 ²
30	5 ²	5 ²	5 ²	5 ²
36	5 ²	5 ²	5 ²	5 ²
42	5 ²	5 ²	5 ²	5 ²
48	5 ²	5 ²	5 ²	5 ²
54	5 ²	5	5 ²	5
60	5	3	5	3
66	5	3	4	3
72	4	3	3	2
78	3	2	2	2
84	4	2	2	1
90	3	2	---	---
96	2	2	---	---
102	2	1	---	---

¹ Contact your local Contech representative for more information about recommended grout pressure and grout procedures.

² Grout pressure limited to 5 psi maximum for practical, safe installation considerations. Higher grouting pressures may be possible and tolerable, depending upon the type of joint system used and other site-specific installation considerations.

* Includes a Factor of Safety (FS) = 3.0 for installed ULTRA FLO liner pipe that is perfectly round or a FS = 2.0 for liner pipe with 5% deflection.



Structures

With a nationwide focus on structurally-deficient and functionally-obsolete bridges, time and cost-effective bridge replacement solutions are in high demand. Contech plate and precast structures have proven records of success for:

- Emergency bridge replacements
- Fast-tracked projects
- Relining and rehabilitation
- Culvert extensions for road widening

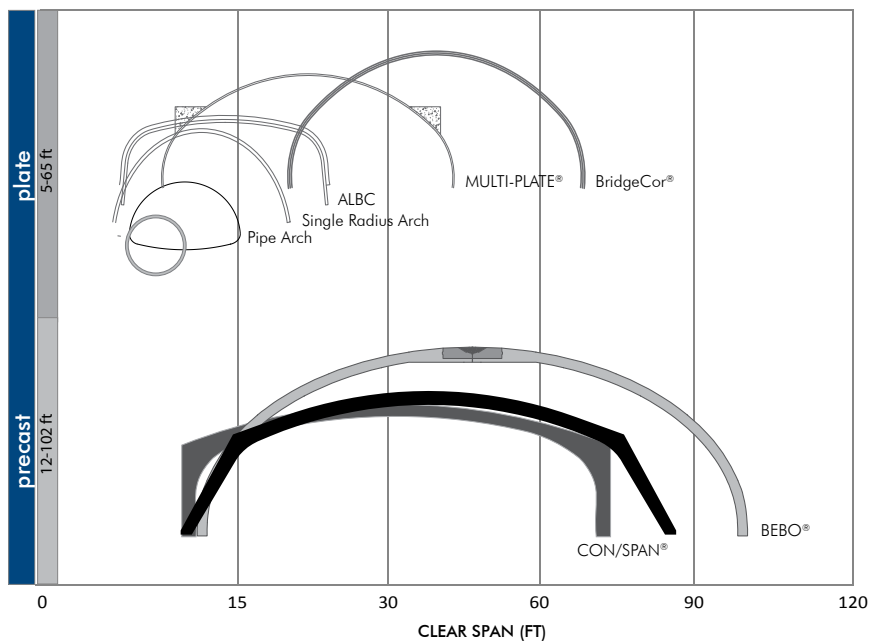

CON/SPAN® and BEBO®

Buried concrete arches provide another alternative for bridge rehabilitation. Precast elements are slid easily underneath existing aging structures to ensure their long-term serviceability.

Because these structures are prefabricated and come with extensive technical support, they allow highway agencies and municipalities to dramatically reduce construction time and traffic disruptions during bridge replacements.

Steel and Aluminum Box Culverts

Box Culverts are a practical and cost-effective solution for small bridge rehabilitation. These wide-span, low-rise shapes are lightweight, making them fast and easy to install.

MULTI-PLATE® and Aluminium Structural Plate

Steel and aluminum structural plate offerings from Contech have a long history of strength, durability and economy. These structures meet a wide range of site-specific challenges with a variety of sizes and shapes available. Additionally, these structures offer unique design elements that include sloped ends, beveled cuts and elbows. Many are suited specifically for rehabilitation due to fast installation accompanied by extensive technical support. These structures provide spans of up to 26 feet.



SUPER-SPAN™, SUPER-PLATE® and BridgeCor®

- Offering larger spans
- A different family of shapes
- Spans of up to 65 feet



Tunnel Liner Plate

Contech Tunnel Liner Plate provides optimum stability and protection when constructing new utility tunnels, relining structures under highways and railroads, and lining vertical shafts. It offers the highest continuous ring stiffness and high compression joint strength. The 2-Flange Liner Plate has effective stiffness that is more than double the stiffness of the same gage of 4-Flange Liner Plate.

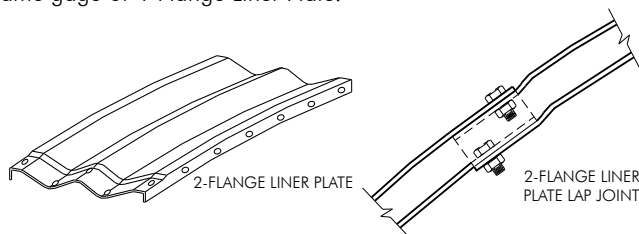

Deep, full-length corrugations and lapped joints for more effective stiffness and ring compression.



Typical Grout Fill for Tunnel Liner Plate

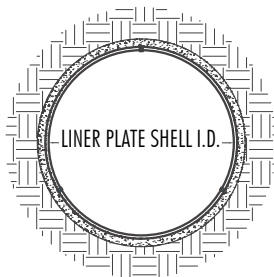

Standard Shapes



Providing Economic Alternatives

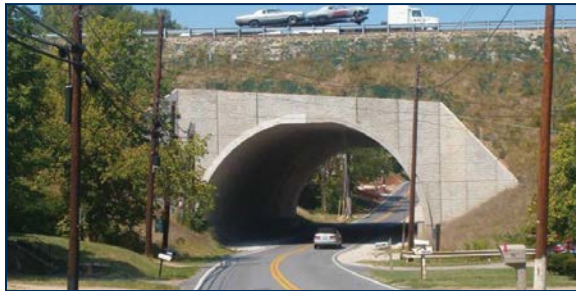

Installation Site

I-64 Bridge Repair
Huntington, West Virginia

Materials

BEBO precast arch structure
54' span, 24'-4" rise and 158' length

Project Details

A buried BEBO Concrete Arch Structure C54 was selected as a value engineering proposal to replace the original I-64 three-span, steel girder bridge.

Roadway closure from 8:00 p.m. to 6:00 a.m. daily during construction, kept local road closure time to a minimum. The original maintenance of traffic scheduled for two construction seasons was reduced to one construction season, providing a huge safety bonus to the traveling public and to the contractor. With lower material costs and faster installation times, BEBO proved to be an economical and successful vehicular overpass solution for the West Virginia Department of Highways.



Installation Site

Route 65 Reline
Carroll County, Missouri

Materials

120" dia. of 10-gage Aluminized Steel Type 2
Corrugated Steel Pipe – 2 runs, 40' long each

Project Details

Aluminized Steel Type 2 Corrugated Steel Pipe was used to reline an existing concrete box culvert on Route 65 – a major four-lane highway in North-Central Missouri. The initial consideration was to remove and replace the existing twin 12'x12' culverts, but this relining alternative proved to be less expensive, provided the quickest turnaround time for construction and was the most convenient for traffic flow on the highway. The Route 65 Reline project was a great success and won an MODOT Practical Design Award in the Small Bridge Replacement category.

Installation Site

CT DOT I-84

Middlebury, Connecticut

Materials

154" to 172" dia. of Galvanized Steel Tunnel Liner Plate and Aluminum Tunnel Liner Plate

Project Details

A 335' long, twin 14' ellipsed steel structural plate pipe structure installed in 1964 under 35' of fill was lined with a galvanized steel Tunnel Liner Plate, with high strength mortar lining for hydraulic efficiency, on the upstream end. On the downstream end, an aluminum Tunnel Liner Plate, without lining, was used to reduce water velocity at outlet. New structures have diameters from 154" to 172". The new structures were designed to carry the full load above. Installed in 2000, photos show this structure in 2012.



Installation Site

MOBILE REGIONAL AIRPORT - RUNWAY 14/32

Mobile, Alabama

Materials

1,500 LF of 120" dia. of DuroMaxx SRPE Pipe

Project Details

The Mobile Airport Authority filed an application with the Federal Aviation Administration to garner a small stipend intended for continued development and rehabilitation for the airport. Part of that involved the rehabilitation of a single 1,740' long, 132" diameter culvert that ran under Runway 14/32.

Given the location, replacement was completely out of the question. The Airport did not want to have to shut down operations while construction was underway. Ultimately, they turned to a 120" diameter DuroMaxx steel reinforced polyethylene (SRPE) liner pipe supplied by Contech Engineered Solutions to slipline into the existing culvert.



The Grouting Process



What is Involved

Grouting of the annular space fixes the position of the new liner pipe, provides uniform support and inhibits further failure of the host pipe. High slump, low-strength grout mix containing fly ash or a cellular grout additive will help ensure all voids are filled. Pre-blended, commercially available products and blown-sand methods are other strategies the contractor may consider.

Contech can provide assistance from conceptual ideas to cost estimates to final shop drawings.

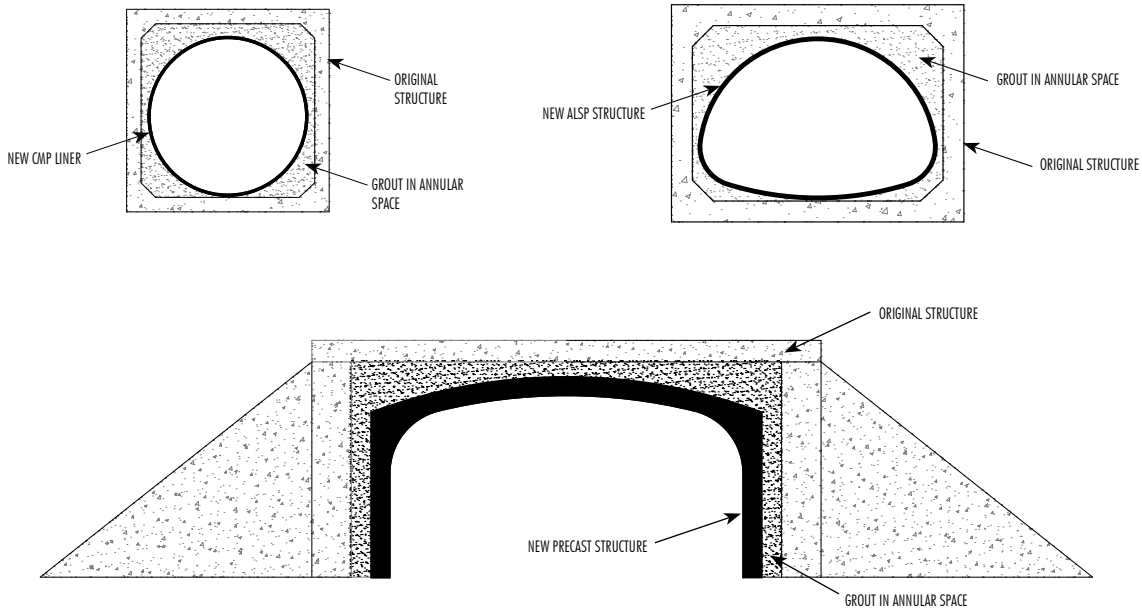

Grouting Techniques

Small Diameters (less than 48") » Grouting Technique

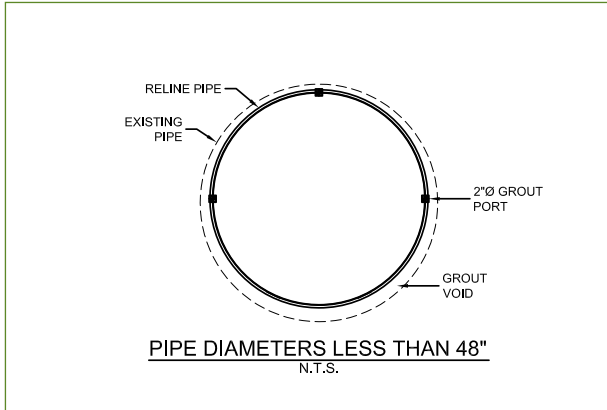

Pipe diameters less than 48" are best suited for a single stage grouting technique.

This is done most efficiently by constructing a bulkhead at the ends of the reline and allowing the new pipe to float to the crown of the existing pipe while grout is pumped into the annular space. Grout should flow in a controlled manner to ensure balanced filling on all sides.



Large Diameters (48" and larger) » Grouting Technique

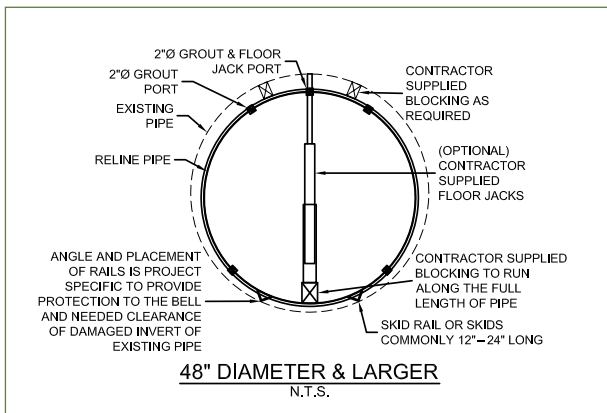

Multiple stage grouting is normally necessary for pipe that is 48" diameter and larger. This approach allows for a large reduction in effective buoyant force of the fluid grout. The technique requires a well-thought bracing and blocking scheme and a full evaluation of shape control, grout slump and mix design and grout pumping rate. Typically, a self-leveling grout product should flow in a controlled manner to ensure balanced filling.



Optional 2" grout ports shown installed in DuroMaxx® Liner Pipe

Multi-Stage Grouting Procedure

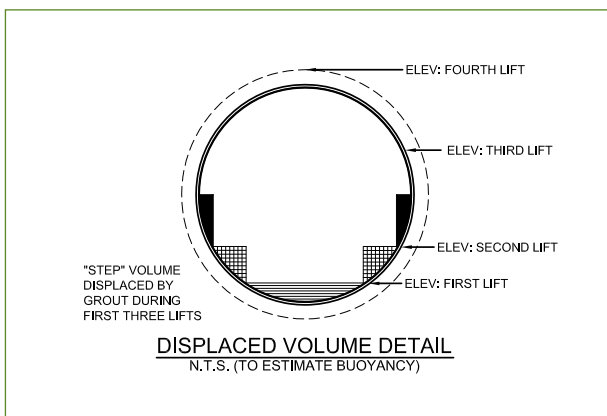

Always use a screen on the pump hopper to sift out any large aggregate that can clog the grout line and potentially damage the structure. For more information, contact your Contech representative.

Spiral Wound Reline Technologies — SPR™ PE

Structural Internal Steel Reinforced HDPE Liner Method for Closed System Storm & Sanitary Sewers and Culverts with Limited Access

SPR™ PE liners can structurally rehabilitate brick, concrete, glass reinforced plastic or corrugated metal pipelines from 36 to 144 inches. SPR™ PE is a steel reinforced plastic pipe liner with a smooth internal surface. The liner is spirally wound into a circular pipe from within the base of the manhole of the pipeline to be rehabilitated. The liner is introduced into the host pipe at a fixed diameter and annular space is subsequently grouted using a cellular or low strength cementitious grout. The plastic profile that forms the liner is reinforced with steel that is fully encapsulated within the HDPE material. The steel reinforcement is selected based on the individual project design requirements.

- Structural liner, strong and lightweight
- Manufactured from pipe grade high density polyethylene (HDPE) with embedded steel reinforcing
- Steel thickness can be varied to vary pipeline stiffness
- Diameters from 30 to 118 inches using three profiles
- Suitable for gravity flow sanitary sewer and storm sewer pipelines
- High chemical resistance
- Industrial applications
- Improved flow with smooth HDPE material (Manning's n of 0.010)
- Installation can occur with up to 25% of the flow present

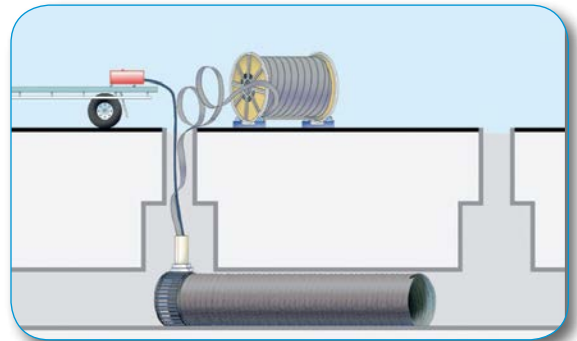

	
	SPR™ PE
Diameter	30" to 118"
Material	HDPE
Shape	Circular
	Fixed diameter

World Wide Project Experience



© 2019 Contech Engineered Solutions LLC, a QUIKRETE Company
All rights reserved. Printed in USA.

Rehab Bro 5M 9/17 MC (PDF - 10/19)

www.ContechES.com | 800-338-1122

NOTHING IN THIS CATALOG SHOULD BE CONSTRUED AS A WARRANTY. APPLICATIONS SUGGESTED HEREIN ARE DESCRIBED ONLY TO HELP READERS MAKE THEIR OWN EVALUATIONS AND DECISIONS, AND ARE NEITHER GUARANTEES NOR WARRANTIES OF SUITABILITY FOR ANY APPLICATION. CONTECH MAKES NO WARRANTY WHATSOEVER, EXPRESS OR IMPLIED, RELATED TO THE APPLICATIONS, MATERIALS, COATINGS, OR PRODUCTS DISCUSSED HEREIN. ALL IMPLIED WARRANTIES OF MERCHANTABILITY AND ALL IMPLIED WARRANTIES OF FITNESS FOR ANY PARTICULAR PURPOSE ARE DISCLAIMED BY CONTECH. SEE CONTECH'S CONDITIONS OF SALE (AVAILABLE AT WWW.CONTECHES.COM/COS) FOR MORE INFORMATION.