

DuroMaxx[®] Steel Reinforced PE Technology
Installation Guide





Preface

This installation guide is for your crews. Distribute it to help them unload, handle and install Contech DuroMaxx® steel reinforced polyethylene (SRPE) pipe safely. DuroMaxx is a flexible pipe that can be installed per the requirements of ASTM D2321, “Standard Recommended Practice for Underground Installation of Flexible Thermoplastic Sewer Pipe.”

Don’t assume that experienced workers know all the answers. Review these instructions with your supervisors and crews. It can mean a safer and better job for you and your customer.

We suggest that, if performance testing of the joints is required, testing the first few manhole runs should be done in the early stages to ensure that jointing procedures are correct. It will give you an early check that installation procedures are correct.

If you have any questions about these instructions, call your Contech Dealer or your Contech Sales Engineer, or carefully review the installation guide and ASTM D2321.

Contents	Page
Safety instructions for unloading & handling	3
Handling weights.....	4
Flotation Prevention	5
Assembly and installation references.....	6
Standard Backfill Detail.....	9
Heavy construction loads.....	10
Cutting Instructions.....	11



This safety alert symbol indicates important safety messages. When you see this symbol, it will alert you to hazards or unsafe practices that CAN result in severe personal injury (including death) or property damage. Be sure you understand the message that follows.

Safety Instructions



Failure to follow these instructions can result in serious injury or death and/or damage to pipe.

1. Only trained and authorized equipment operators are to be permitted to unload the trailer.
2. Wear approved safety hat, shoes, gloves and eye protection.
3. Park the truck and trailer on level ground before you start unloading.
4. Keep all unauthorized persons clear of the area when the driver releases the binders from the trailer and during unloading.
5. Do not release strapping around the wood frame until the pallets or bundles have been placed on level ground and will not be moved again as a unit.
6. On nested loads, cut the internal strapping prior to unloading.
7. Know the capabilities and rated load capacities of your lifting equipment. Never exceed them.
8. Do not stand or ride on the load of pipe while it is being unloaded.
9. If unloading at multiple points, secure pallets between drop off points. Always unload the top pallets first. (See illustration at right.)
10. Never attach chains or cable to the pipe. They could damage the pipe.
11. Do not push pallets off the trailer or permit pipe to drop to the ground.
12. Do not stack DuroMaxx pipe.
13. Only use recommended unloading poles to lift pipe. Unauthorized unloading pole can lead to unsafe practices and damaged pipe.
14. **Falling or rolling pipe can cause severe personal injury or death. Notwithstanding the instructions contained in this booklet, it is the responsibility of the consignee or consignee's agent to devise safe unloading and handling procedures.**
15. **Do not lift from the steel strapping.**
16. **Do not stand beneath or near the pipe while it is being unloaded.**
16. **Always follow all project, local, state and OSHA rules and safety requirements including but not limited to confined space, trenching, shoring and excavation procedures.**

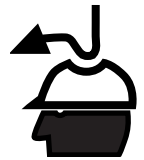
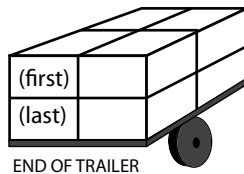

WARNING

WARNING

Handling Weights

Approximate weight (pounds/lineal foot). These are estimated average weights and are not for specification use.

TABLE 1. DIMENSIONS & HANDLING WEIGHTS				
Pipe Dia. (in)	Outside Dia. (in)	Inside Dia. (in)	Bell Outside Dia. (in)	Approx. Weight (lbs/ft)
30	30.9	29.5	34.0	18.8
36	37.1	35.4	39.9	23.6
42	43.2	41.3	45.8	27.0
48	49.5	47.2	52.3	30.8
54	55.5	53.2	58.2	36.1
60	61.4	59.1	64.1	42.9
66	67.8	65.0	NA	56.9
72	74.1	70.9	77.6	65.6
84	85.9	82.7	NA	76.3
96	97.8	94.5	NA	87.0
108	111.3	108	NA	99.7
120	121.9	118.1	NA	109.0



- Use Nylon lifting slings of sufficient strength, length and specifically intended to safely handle entire pallet or individual pipe, whichever is being lifted.
- For 30" diameter pipe, one sling point located at mid-length is generally sufficient.
- Use two (2) sling points for lifting sizes greater than 30" diameter. Sling spacing equal to 1/3rd of the pipe length is generally sufficient.

Unloading and Handling

Read and follow all safety instructions before unloading pipe.

- Before unloading, observe the pipe for damage while it is still on the truck. Note any pipe damage on the bill-of-lading and have the truck driver initial the notes. Also, report any shipping damage to your local Contech representative.
- Do not** overtighten strapping as it may cause dimpling. If dimpling occurs, unstrap pipe to allow for rebound to occur at the dimpling of the pipe.
- On nested loads**, cut the internal strapping prior to unloading. Unload each pipe size independently.
- Use a forklift with full-length forks or fork extensions (typically 8 feet), front-end loader or backhoe with fork adapters at full length to engage entire pallet width. Make sure back of forklift is free of protrusions or spikes that could damage the pipe.



- Recommended unloading pole can be used inside the pipe to unload and handle individual pipe sections. Using forks or unapproved poles inside the pipe will result in damage.
- Do not** use steel cables, chains and/or hooks to unload or handle pipe.
- Do not** stand or ride on the pipe load during unloading or handling.
- Do not** scoop the pipe or strike with forks.
- Do not** drag or drop the pipe.
- Proper on-site bell and spigot pipe storage practices and blocking should be used to avoid deformation of the pipe bells.



Trench Dimensions

Trenching practices shall be in accordance with OSHA.

1. The trench needs to be wide enough for a person to work safely.
2. Where trench walls are unstable, the contractor may elect to use tight sheeting, bracing, or a trench box for stabilization during pipe laying. If the conditions are severe, sheeting may be left in place.
3. Refer to ASTM D2321, Paragraph 6.4.2, for proper placement and movement of trench boxes. Improper use of trench boxes can affect pipe performance.



Groundwater

1. Excessive groundwater may necessitate dewatering. Dewatering techniques must meet all OSHA and local requirements and codes.
2. In areas of saturated trench conditions or in dewatered trenches, refer to "Foundation and Bedding," and ASTM D2321 for proper selection of bedding and backfill materials.
3. Flotation of the pipe and erosion or wash-out of previously placed soil support must be prevented to ensure that the structure maintains its load carrying capacity.
4. Contact the Engineer of Record, hereinafter referred to as "engineer," for proper cover to prevent flotation.

TABLE 2. MINIMUM COVER NEEDED TO PREVENT FLOTATION

Pipe Dia. (in)	Cover Required
30	1'-4"
36	1'-7"
42	1'-10"
48	2'-2"
54	2'-5"
60	2'-8"
72	3'-2"
84	3'-9"
96	4'-3"
108	5'
120	5'-5"

Foundation and Bedding

1. An unstable trench bottom must be stabilized at the engineer's direction. In such cases, install special foundation and bedding materials in 6 inch layers and compact.
2. Excavation below the final loosely placed bedding material shall be compacted using standard bedding practices or compacted at a minimum of 90% Standard Proctor Density.

- The final bedding material provides uniform support to hold the pipe on line and grade. A relatively loose 4" to 6" thick bedding layer is usually adequate. Before installing the pipe, bring bedding material to grade along the entire length of the pipe. Bedding materials can be Class I, II or III per ASTM D2321.



- When excavating in Class IV materials (silts, silty clays and clays), provide a uniform, undisturbed foundation.
- Class IA materials if used for bedding, must be used as haunching material to the spring line in a dry trench. To minimize the potential for migration, Class IA materials should be used to the top of the pipe in wet trenches or in trenches that will fall below the water table.

Assembly of Pipe (Joining)

- Pipe is typically joined by inserting the spigot into the bell. When jobsite conditions require putting the bell on to the spigot, care should be taken not to scoop up backfill material into the joint during jointing.
- The double sealing gasket is fitted into the spigot valleys as shown in the drawing below. A white line on the front of the gasket will be visible if not properly seated.
- Make sure the bell and spigot joint is thoroughly clean and free of soil of any type.

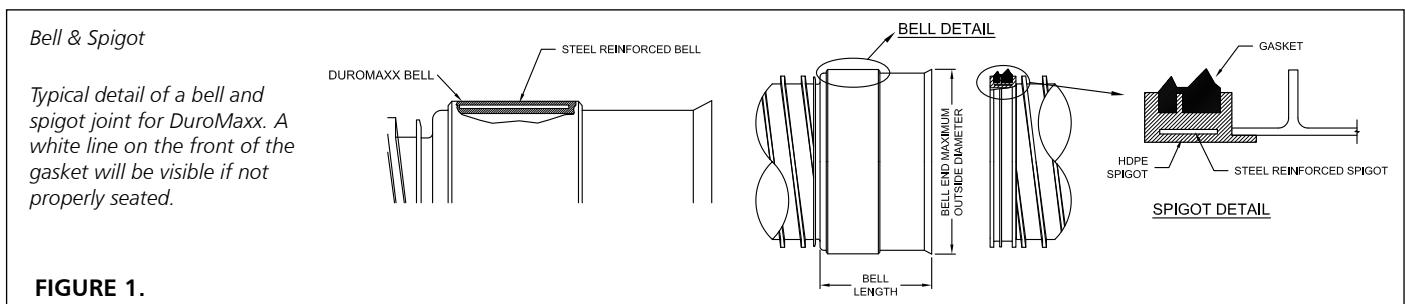

- Be sure to apply a generous amount of gasket lube to the gasket and to swab the inside of the bell. The most common application method is with a rubber glove although johnny mops can be used for smaller diameter pipe.
- Dig out a "**bell hole**" beneath the entire bell and extend approximately 8" beyond the leading edge of the bell end's edge with a shovel or boot heel in order to keep the spigot free of bedding material and to prevent materials from being pulled in to the bell by the spigot. Materials pulled in to the bell can impair gasket sealing and cause leaks.

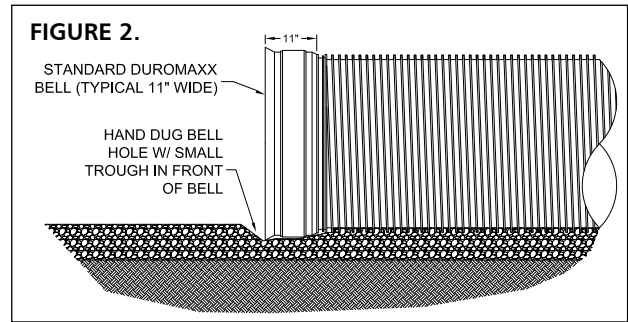

- After creating a bell hole and prior to joint connection, laying a piece of reusable matting or plastic liner in front of the joint will eliminate stone and/or backfill from being scooped or dragged into the joint. Remove the matting after joint is home.



- Align the spigot end of the pipe into the bell's leading edge during joining process. Straight alignment of the joint ends will minimize the possibility of rolling the gasket.
- Do not push on the bell end of the pipe! Do not use a cable or chain wrapped around the pipe to join the pipe. Use of a nylon strap to pull the pipe is strongly advised.

- The spigot end of the pipe features a "homing mark" that will align with the end of bell when the spigot has been fully inserted into the bell.



- Once the pipe has been fully placed in the trench and prior to backfilling, it is recommended that the Engineer or a qualified representative of the Engineer approve the trench, bedding and placement of the pipe.
- After the joint is homed, hand shovel and shovel slice the bedding (i.e. fill and compact) to fill the bell hole for uniform support.**
- Cold Weather Note:** Rubber gaskets become harder as the ambient temperature decreases. Gaskets tend to compress less, and when combined with bells, jointing becomes less forgiving. Proper bell-spigot alignment, adequate bell and spigot lubrication and recommended joining procedures all become more essential as temperatures decreases.
- After proper assembly, take precautions to prevent the pipe from movement prior to haunching and backfilling.

Welded Joint Considerations

- It is critical that the pipe be kept dry.
- For proper welded coupling, misalignment should not exceed 0.25 in.
- It is critical that the gap between pipe ends should not exceed 1.5 in. for proper coupling.
- Please conform to OSHA confined space requirements.

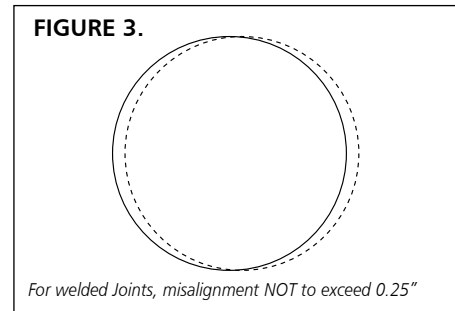

Haunching

- Proper haunching provides a major portion of the pipe's load-carrying capability. Poor workmanship will lead to excessive pipe deflection and grade and alignment problems. Haunching materials can be Class I, II, or III per ASTM D2321.
- Work enough material under the haunch of the pipe by hand to provide proper compaction and side support. Material shall meet the minimum compaction requirements of ASTM D2321.
- When trench walls are unstable, sloughing must be prevented so that haunching material can be placed and compacted adequately. The proper use of a trench box or over-excavation can assist in these cases.
- Don't let the pipe move when placing material under the haunch of the pipe.
- Take care not to damage the pipe with shovels, or other construction/tamping equipment.
- Haunch material extends from the bedding/foundation material to the springline elevation.

Backfill and Compaction

- Initial backfill materials extend from the springline to above the pipe (see page 9 -Standard Backfill Detail) to provide the remainder of the pipe support and protect the pipe from stones or cobbles in the final backfill. Backfill materials that generally follow the requirements of ASTM D2321, such as Class I, II, or III (or approved equal) may be used.
- Native materials meeting the acceptable materials on page 8 can be used as backfill, but should be approved by the Engineer.
- Materials must be free from large stones, frozen lumps or other debris.
- Typical trench/backfill details can be found on page 9; and acceptable backfill materials and compaction requirements on page 8 in this document.

5. Select fill should be placed and compacted to the minimum thickness referenced in the applicable installation detail before transitioning to native or non-select fill material over the pipe or to pavement.
6. Fill above the select fill should be fully compacted.
7. As backfill is placed around the pipe, care should be taken to avoid damage to the pipe.
8. Backfill height differential from one side of pipe to the other shall not exceed 12". Only "hand compaction" equipment is allowed over and around the pipe until minimum construction heights are achieved.

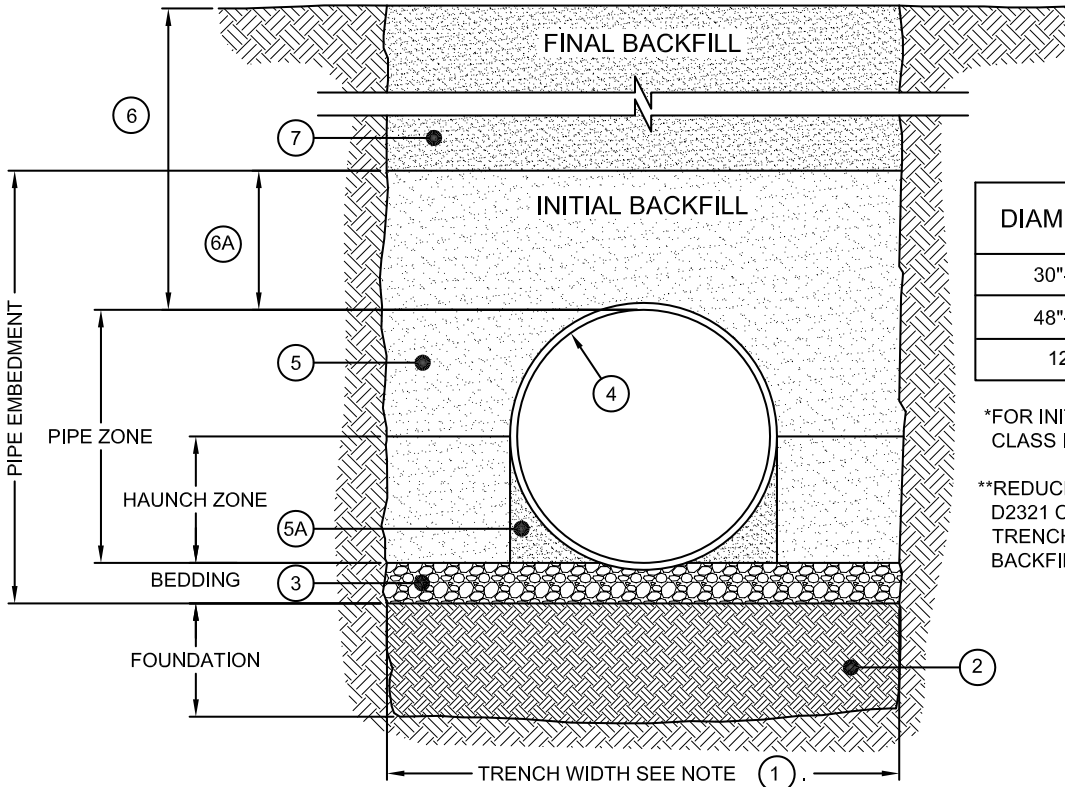

TABLE 3. ACCEPTABLE BACKFILL MATERIALS AND COMPACTION REQUIREMENTS

DESCRIPTION	SOIL CLASSIFICATIONS				MINIMUM STANDARD PROCTOR DENSITY %
	ASTM D2321	ASTM D2487	AASHTO M43	AASHTO M145	
Graded or crushed, crushed stone, gravel	Class I	-	5 56	A-1-a	85%
Well-graded sand, gravels and gravel/sand mixtures; poorly graded sand, gravels and gravel/sand mixtures; little or no fines	Class II	GW GP SW SP	57 6	A-1-b A-3	85%
Silty or clayey gravels, gravel/sand/silt or gravel and clay mixtures; silty or clayey sands, sand/clay or sand/silt mixtures	Class III	GM GC SM SC	Gravel and sand (<10% fines)	A-2-4 A-2-5	90%

Use of cementitious or flowable backfills is compatible with DuroMaxx. Proper precautions should be taken to preclude flotation of the pipe. Contact your Contech representative for further guidance.

Standard Backfill Detail - Specification & Standard Drawing



*FOR INITIAL BACKFILL USE ASTM D2321, CLASS I, II MATERIAL.

**REDUCED MAX. COVER WHEN USING ASTM D2321 CLASS III MATERIAL IN TRENCH/HAUNCH ZONE OR FOR FIRST BACKFILL.

- ① MINIMUM TRENCH WIDTH MUST ALLOW ROOM FOR PROPER COMPACTION OF HAUNCH MATERIALS UNDER PIPE. MIN. WIDTH = (1.25 x DIAMETER) + 12" (FOLLOW ASTM D2321)
- ② FOUNDATION SHALL BE WELL CONSOLIDATED & STABLE.
- ③ BEDDING MATERIAL SHALL BE A RELATIVELY LOOSE MATERIAL THAT IS ROUGHLY SHAPED TO FIT THE BOTTOM OF THE PIPE, 4" TO 6" IN DEPTH.
- ④ DUROMAXX STEEL REINFORCED (SRPE) PIPE.
- ⑤ INITIAL BACKFILL FOR PIPE EMBEDMENT MATERIAL TO MEET ASTM D2321 CLASS I, II, III OR APPROVED EQUAL, COMPACTED TO 90% STANDARD PROCTOR (NATIVE MATERIAL CAN BE UTILIZED THAT MEETS ASTM D2321 OR APPROVED EQUAL).
 - ALL LIFTS PLACED IN CONTROLLED MANNER. TO PREVENT UNEVEN LOADING, IT IS RECOMMENDED THAT LIFTS NOT EXCEED 8" UNCOMPACTED LIFT HEIGHTS.
- ⑤A HAUNCH ZONE MATERIAL SHALL BE HAND SHOVELED OR SHOVEL SLICED INTO PLACE TO ALLOW FOR PROPER COMPACTION.
- ⑥ MINIMUM HEIGHT OF COMPACTED COVER PER DIAMETER FOR CONVENTIONAL HIGHWAY LOADS (DISTANCE MEASURED FROM TOP OF PIPE TO BOTTOM OF FLEXIBLE PAVEMENT OR TOP OF RIGID PAVEMENT):
 - 12" MINIMUM FOR PIPE DIAMETERS 30" - 60"
 - 18" MINIMUM FOR PIPE DIAMETER 66" - 72"
 - 24" MINIMUM FOR PIPE DIAMETERS 84" - 96"
 - 36" MINIMUM FOR PIPE DIAMETER 120"
- ⑥A INITIAL BACKFILL ABOVE PIPE MAY BE REDUCED AS NOT TO ENCROACH UPON ROAD BASE, OTHERWISE:
 - 6" MINIMUM FOR PIPE DIAMETERS 30" - 60"
 - 12" MINIMUM FOR PIPE DIAMETERS 66" - 96"
 - 18" MINIMUM FOR PIPE DIAMETER 120"
- ⑦ FINAL BACKFILL MATERIAL SELECTION AND COMPACTION REQUIREMENTS PER THE PROJECT PLANS, SPECIFICATIONS, ENGINEER OF RECORD.

NOTES:

- GEOTEXTILE SHALL BE USED AS REQUIRED TO PREVENT SOIL MIGRATION.
- FOR MULTIPLE BARREL INSTALLATION THE RECOMMENDED STANDARD SPACING BETWEEN PARALLEL PIPE RUNS SHALL BE = PIPE DIA./2 OR 3' FOR PIPE DIAMETERS 72" AND LARGER. CONTACT YOUR CONTECH REPRESENTATIVE FOR NONSTANDARD SPACING.
- BACKFILL REQUIREMENTS SHALL FOLLOW ASTM D2321. IN THE EVENT OF DISCREPANCIES, ASTM D2321 SHALL SUPERCEDE THIS DETAIL.

Flowable Fill

These materials are suitable for use with DuroMaxx at the direction of the Engineer. The contractor must take precautions to preclude the dislocation or flotation of the pipe during placement of the flowable fill. Should these materials be utilized by the contractor, Contech will assist with recommendations for restraint to ensure line and grade can be maintained.

Embankment Conditions

1. DuroMaxx is a superior product that is normally installed in a trench condition. Embankment installations are an acceptable installation application.
2. In general, the backfill type and placement of the backfill immediately around the pipe can be the same as that shown on page 8.
3. The width of the select fill zone around the pipe and the type of material placed outside the zone – adjacent to the select fill zone – are critical and dependent upon the pipe diameter and ultimate amount of fill and loads to be placed over the pipe.
4. In the event of an embankment installation, a backfill design should be prepared for the specific site conditions by the Engineer.
5. Larger diameters may not be allowed or may require additional care in backfilling. Only small walk-behind compaction equipment should be used directly around the pipe.

Cover Limits

Once the backfilling process is completed, the contractor should take care to maintain the minimum allowable cover height over the pipe and should notify all other contractors and subcontractors to avoid removal of fill cover or rutting.

TABLE 4. HEIGHT OF COVER LIMITS H20-25/HS20-25		
Pipe Dia. (in)	Min. Cover (ft)	Max. Cover (ft)
30-42	1	50
48-60	1	30
66-72	1.5	30
84-96	2	30
108	2.5	25
120	3	25

NOTES

1. Allowable minimum cover is measured from the top of the pipe to the bottom of a flexible pavement or the top of the pipe to the top of a rigid pavement. Minimum cover in unpaved areas will be greater than for paved areas shown in Table 2 and must be maintained. Contact your local Contech Sales Engineer for more information.
2. All heights of cover are based on trench conditions. If embankment conditions exist, additional care in the placement of fill outside the pipe backfill zone is required. Your Contech representative can provide further guidance for a project in embankment conditions.

Construction Loads

TABLE 5. HEAVY CONSTRUCTION LOADS				
Minimum Height of Cover Requirements for Construction Loads. The Minimum Cover should be a COMPACTED Height of Cover Requirement.				
Diameter/Span (in)	Axle Load (Kips)			
	>32 ≤50	50 ≤75	75 ≤100	110 ≤150
30-42	2.0 ft	2.5 ft	3.0 ft	3.0 ft
48-72	3.0 ft	3.0 ft	3.5 ft	4.0 ft
84-96	3.0 ft	3.5 ft	4.0 ft	4.5 ft
108-120	3.5 ft	4.0 ft	4.5 ft	5.0 ft

1. For temporary heavy construction vehicle loads, an extra amount of minimum compacted cover may be required over the top of the pipe.
2. The height-of-cover shall meet the minimum requirements shown in the Table 4. The contractor must provide the additional cover required to avoid damaging the pipe.
3. Minimum cover, shown in Table 4, is measured from the top of the pipe to the top of the maintained roadway surface.
4. The contractor should notify all other contractors and subcontractors to avoid any off-highway or unusual live loads (construction loads) over the pipe. The loads would include but are not limited to: off-highway trucks, earth movers or scrapers, certain paving and other construction equipment.

FIGURE 4

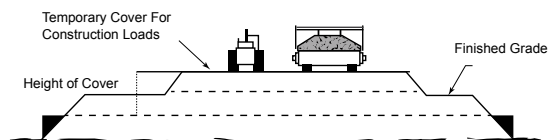

Maximum Allowable Tracked Vehicle Loads for DuroMaxx® SRPE

The minimum cover specified for a project normally assumes H-20 highway live loading. Backfill must be placed and fully compacted to the minimum cover level over the structure before the pipe is subjected to design loads. Construction loads often exceed design highway loading. During construction, keep heavy construction equipment that exceeds legal highway loads off the pipe.

Values in the table below represent the maximum ground pressure permitted when performing reasonable work over the pipes, using the manufacturer's published equipment specifications. (Ground pressure for tracked equipment is the vehicle operating weight divided by the total ground contact area for both tracks). This table is to be used as a guide. Talk to your Contech representative if you have questions about the equipment you plan on operating over the pipes. Care should be taken to maintain adequate cover depth during construction activities.

Minimum Height of Cover Requirements for Tracked Loading DuroMaxx® SRPE					
Diameter	Minimum Cover (Ft)	Track Width (inches) Maximum Track Pressure at Surface (psi)			
		12	18	24	30
30	1.0	43	32	28	25
	1.5	86	61	50	44
	2.0	139	95	76	65
	2.5	204	134	104	87
	3.0	278	177	134	111
	4.0	469	286	209	168
36	1.0	35	26	22	20
	1.5	69	50	41	36
	2.0	113	78	61	53
	2.5	166	109	84	71
	3.0	226	144	109	90
	4.0	383	233	171	137
42	1.0	29	22	19	17
	1.5	58	41	34	30
	2.0	95	65	51	44
	2.5	139	91	71	59
	3.0	190	121	92	76
	4.0	322	196	143	115
48	1.0	18	14.0	12.0	10.8
	1.5	37	26	21	18
	2.0	60	41	32	27
	2.5	87	57	44	37
	3.0	119	76	58	47
	4.0	203	124	90	73
54	1.0	16	12.1	10.4	9.3
	1.5	31	23	18	16
	2.0	52	35	28	24
	2.5	76	50	38	32
	3.0	104	66	50	41
	4.0	176	107	78	63
60	1.0	14.8	11.1	9.5	8.5
	1.5	29	21	17	15
	2.0	48	32	25	22
	2.5	69	45	35	29
	3.0	95	60	45	37
	4.0	162	98	72	58

Minimum Height of Cover Requirements for Tracked Loading DuroMaxx® SRPE					
Diameter	Minimum Cover (Ft)	Track Width (inches) Maximum Track Pressure at Surface (psi)			
		12	18	24	30
66	1.0	12.5	9.5	8.1	7.3
	1.5	28	20	16	14.4
	2.0	45	31	24	21
	2.5	67	44	34	28
	3.0	91	58	43	36
	4.0	123	95	69	55
72	1.0	9.7	7.4	6.3	5.6
	1.5	23	16	13.8	12.1
	2.0	38	26	20	17
	2.5	56	37	28	23
	3.0	76	48	36	30
	4.0	131	80	58	47
84	1.0	7.4	5.6	4.7	4.3
	1.5	20	14.6	11.9	10.4
	2.0	33	22	18	15
	2.5	49	32	24	20
	3.0	66	42	32	26
	4.0	114	69	50	40
96	1.0	5.1	3.9	3.4	3.0
	1.5	14.8	10.3	8.4	7.3
	2.0	25	17	13.8	11.8
	2.5	37	24	18	15
	3.0	50	32	24	20
	4.0	88	53	39	31
108	1.0	3.7	2.9	2.4	2.2
	1.5	10.2	7.2	5.9	5.1
	2.0	20	13.8	10.9	9.3
	2.5	29	19	14.9	12.4
	3.0	40	25	19	15
	4.0	69	42	31	24
120	1.0	2.8	2.3	1.9	1.7
	1.5	7.4	5.3	4.4	4.1
	2.0	16	11.1	8.8	7.5
	2.5	24	15	12.0	10.1
	3.0	32	20	15	12.9
	4.0	56	34	25	20

- Tracked dozers don't exhibit the same variability in pressures under their tracks as other pieces of construction equipment. Therefore, the maximum track pressures shown above can be increased by a multiplier of 2.5 when applied to tracked dozers.
- The track widths shown above are for single tracks. If your equipment has different track widths, use the width that most closely corresponds to your equipment or extrapolate from the widths shown.

Joint Testing

Be sure to apply lube to the spigot gasket and the inside of the bell of every joint made to ensure a proper connection. Do not pull debris into the bell along with the lubricated spigot. A bell hole may be needed in order to achieve this. All pipe must be free of damage of any kind. **DO NOT fill DuroMaxx tank with liquid without being 100% backfilled.**

Temperature Effects

1. DuroMaxx is a superior product and the pipe's stiffness is not affected by solar absorption or elevated ambient temperatures.
2. If large swings in temperature occur from the location the pipe is stored and the bottom of the trench, then the pipe may require conditioning to avoid contraction of the pipe's length.
3. Operating temperatures are not recommended beyond 120° F (49° C).

Manhole or Structure Connections

DuroMaxx can be connected to manholes or other types of structures using typical methods used by other flexible pipe products. Please consult the Engineer and your local Contech Sales Engineer to discuss what method is most appropriate for the application.

For fixed manhole or structure connections, stack-up of pipe tolerance, line and grade variations and thermal effects should be considered when ordering total pipe lengths.

Cutting Instructions

1. The recommended cutting tool for DuroMaxx pipe is a chop saw and abrasive saw blade. Refer to the Operating Instructions from the saw manufacturer for additional information.



2. Blade thickness should be no less than 1/8" thick and is recommended to be made of 2 ply material that is used to cut ductile iron pipe.

3. Use the leading edge of the blade to cut into the ribs of the pipe.
4. Bury the blade as much as possible into the pipe as you proceed.
5. The alternative cutting tool for DuroMaxx is a handheld reciprocating saw. This process will take about 2 minutes to cut the steel ribs. There are 9 ribs for 24" around the pipe circumference.
6. For large diameters, square cuts can be achieved from the inside.



⚠ Always use safety glasses when cutting DuroMaxx pipe and use protective gloves in case sharp edges are exposed.

Repairs

1. Should damage to the pipe occur at any point during installation, the Engineer should be contacted immediately.
2. For larger damaged sections, cut out damaged areas and cut a length of replacement pipe to fit.
3. Similar to other flexible pipe products, DuroMaxx can be coupled using various industry standard methods and materials (e.g. concrete collars, Fernco® Inc., Mar Mac® or equal).
4. For smaller abrasions or exposed steel, an approved rubberized undercoating spray can be used to cover the steel.

Taps

1. DuroMaxx pipe can be supplied with standard prefabricated taps fittings or components per job plans once pre-fabrication drawings are reviewed by Contech Engineering and approved by the Engineer.
2. DuroMaxx can be field tapped using readily available products for drainage projects. Please contact your Contech Representative for more information.



CONTECH[®] ENGINEERED SOLUTIONS

© 2022 CONTECH ENGINEERED SOLUTIONS LLC, A QUIKRETE COMPANY

800-338-1122

WWW.CONTECHES.COM

ALL RIGHTS RESERVED. PRINTED IN THE USA.

CONTECH ENGINEERED SOLUTIONS LLC PROVIDES SITE SOLUTIONS FOR THE CIVIL ENGINEERING INDUSTRY. CONTECH'S PORTFOLIO INCLUDES BRIDGES, DRAINAGE, SANITARY SEWER, STORMWATER AND EARTH STABILIZATION PRODUCTS. FOR INFORMATION ON OTHER CONTECH DIVISION OFFERINGS, VISIT WWW.CONTECHES.COM OR CALL 800-338-1122.

SUPPORT

DRAWINGS AND SPECIFICATIONS ARE AVAILABLE AT WWW.CONTECHES.COM

DMX Installation Guide 11/22

NOTHING IN THIS CATALOG SHOULD BE CONSTRUED AS A WARRANTY. APPLICATIONS SUGGESTED HEREIN ARE DESCRIBED ONLY TO HELP READERS MAKE THEIR OWN EVALUATIONS AND DECISIONS, AND ARE NEITHER GUARANTEES NOR WARRANTIES OF SUITABILITY FOR ANY APPLICATION. CONTECH MAKES NO WARRANTY WHATSOEVER, EXPRESS OR IMPLIED, RELATED TO THE APPLICATIONS, MATERIALS, COATINGS, OR PRODUCTS DISCUSSED HEREIN. ALL IMPLIED WARRANTIES OF MERCHANTABILITY AND ALL IMPLIED WARRANTIES OF FITNESS FOR ANY PARTICULAR PURPOSE ARE DISCLAIMED BY CONTECH. SEE CONTECH'S CONDITIONS OF SALE (AVAILABLE AT WWW.CONTECHES.COM/COS) FOR MORE INFORMATION.

DuroMaxx[®] is a registered trademark of Contech Engineered Solutions LLC. Mar Mac[®] is a registered trademark of Mar Mac Construction Products, Inc. Fernco[®] is a registered trademark of Fernco, Inc. Inserta Tee[®] is a registered trademark of Inserta Fittings Co.