

# Underground Vaults

- Proven cost advantage compared to alternative underground storage solutions
- Quality assured through controlled conditions for plant-produced product
- Fast installation
- Designed for highway loading above structure
- Comprehensive engineering support

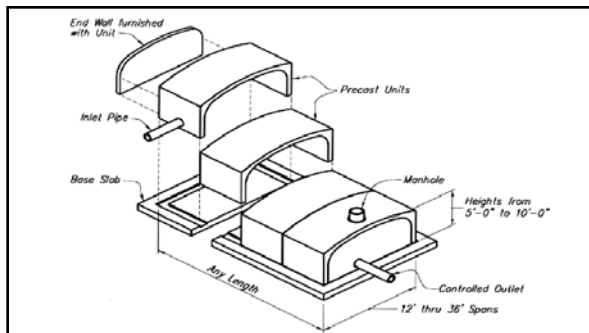

**Retention vault**



**Sedimentation vault** – interior view illustrates accommodations for large openings (New Hampshire)



**Glycol recovery tank** – twin 96-ft-long Glycol recovery tanks for the Greater Cincinnati Int'l Airport (Kentucky)



**Bunker** – the portable demolitions training bunker uses minimal existing space at West Point Academy (New York)



**Wine cave** – multiple cells with earthen floor support natural temperature and humidity control (Oregon)



**Retention vault** – features pressure-resistant joints to prevent infiltration due to high water table (Florida)



**Sedimentation vault** – before backfill, the exterior view shows the integral endwall included in the design (New Hampshire)



**Containment vault** – provide above-ground containment benefits to buried chemical storage tanks (Ohio)

CONTECH Construction  
Products Inc.

9025 Centre Pointe Dr.  
Suite 400  
West Chester, OH 45069  
800-338-1122

www.contech-cpi.com

© 2009 CONTECH Construction Products Inc.