



CONTECH[®]
ENGINEERED SOLUTIONS

CONTECH
ENGINEERED SOLUTIONS
www.ContechES.com

The Stormwater Management StormFilter[®]



The experts you need to solve your stormwater challenges



Contech is the leader in stormwater solutions, helping engineers, contractors and owners with infrastructure and land development projects throughout North America.

With our responsive team of stormwater experts, local regulatory expertise and flexible solutions, Contech is the trusted partner you can count on for stormwater management solutions.

Your Contech Team



STORMWATER CONSULTANT

It's my job to recommend the best solution to meet permitting requirements.



STORMWATER DESIGN ENGINEER

I work with consultants to design the best approved solution to meet your project's needs.



REGULATORY MANAGER

I understand the local stormwater regulations and what solutions will be approved.



SALES ENGINEER

I make sure our solutions meet the needs of the contractor during construction.

Contech is your partner in stormwater management solutions



Flexible Stormwater Filtration Technology

As stormwater quality regulations become more stringent, engineers need a filtration device that can tackle the most challenging pollutants and provide the flexibility to meet the needs of a variety of sites.

The Stormwater Management StormFilter® is an underground stormwater treatment device comprised of one or more structures that house rechargeable, media-filled cartridges that trap particulates and adsorb pollutants from stormwater runoff such as total suspended solids, hydrocarbons, nutrients, metals, and other common pollutants. With media options to target multiple or specific pollutants, multiple system configurations, and field and laboratory performance verified by the most stringent stormwater technology evaluation organizations; the StormFilter provides engineers the most flexible and most reliable manufactured treatment technology available.

An 8' x 24' Stormwater Management StormFilter with 60 cartridges is used to remove pollutants from runoff at Surfers Point Beach in Ventura, California.

The Stormwater Management 
StormFilter®

How the StormFilter Treats Stormwater

During a storm, runoff passes through the filtration media and starts filling the cartridge center tube. The air inside the hood is purged through a one-way check valve as the water rises. When water reaches the top of the float, buoyant forces pull the float free and allow filtered water to exit the cartridge. A siphon is established within each cartridge that draws water uniformly across the full height of the media bed ensuring even distribution of pollutants and prolonged media longevity. After the storm, the water level in the structure starts falling. A hanging water column remains under the cartridge hood until the water level reaches the scrubbing regulators at the bottom of the hood. Air then rushes through the regulators, breaking the siphon and creating air bubbles that agitate the surface of the filter media, causing accumulated sediment to settle on the treatment bay floor. This unique surface-cleaning mechanism prevents surface blinding and further extends cartridge life.

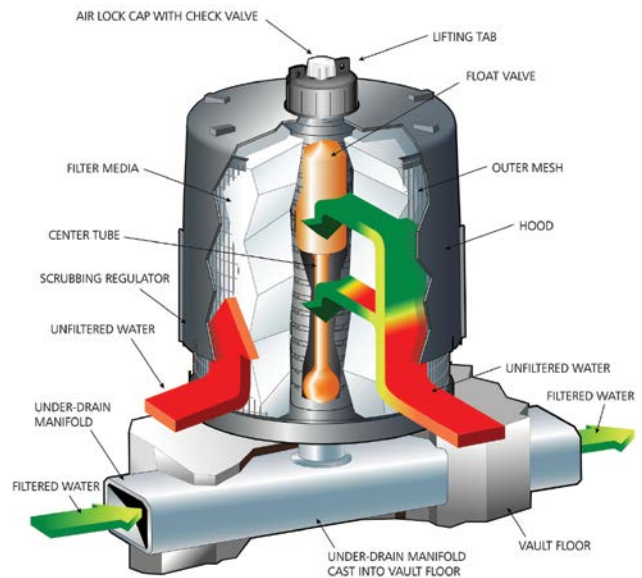

Learn More:
www.ContechES.com/stormfilter

The StormFilter has a 20+ year history of successful installations and over 200,000 cartridges installed worldwide.

FEATURE	BENEFIT
Siphon actuated, high surface area media cartridges	Stormwater is drawn evenly through the filter media providing efficient, effective stormwater treatment
Multiple cartridge heights	Flexibility to meet site-specific hydraulic needs and reduce system size and costs
Multiple media options	Ability to target specific pollutants of concern including TSS, phosphorus, heavy metals, and hydrocarbons
Internal peak bypass and multiple configurations	Design flexibility to meet your unique site requirements
Maintenance intervals of one to five years	Fewer maintenance events and reduced long-term ownership costs
Performance verified by both the WA DOE and NJ DEP	Superior pollutant capture with confidence
Arrives to the jobsite fully assembled	Factory build ensures quality and a simple, fast installation onsite

Design flexibility to meet your unique site requirements

StormFilter Media Options

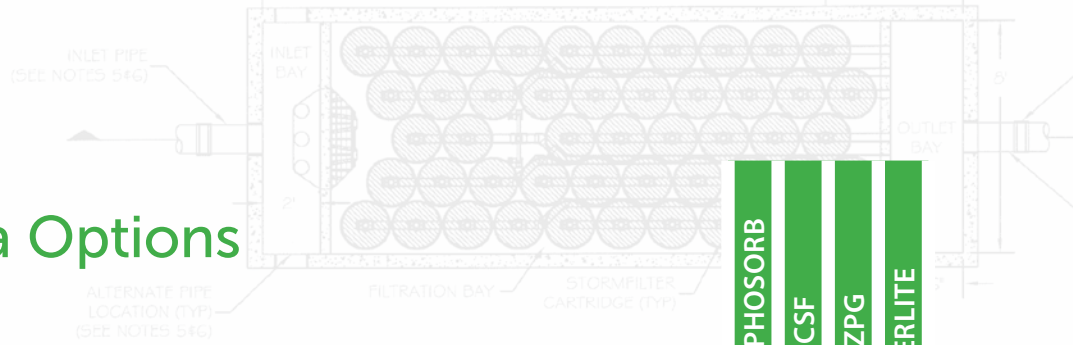

Flexibility to target site-specific pollutants ...

- PhosphoSorb® is a lightweight media built from a Perlite-base that removes total phosphorus (TP) by adsorbing dissolved-P and filtering particulate-P simultaneously.
- CSF® Leaf Media is created from deciduous leaves processed into granular, organic media. CSF is most effective for removing soluble metals, TSS, oil and grease, and buffering acid rain.
- Perlite is naturally occurring puffed volcanic ash. Effective for removing TSS, oil, and grease.
- Zeolite is a naturally occurring mineral used to remove soluble metals, ammonium, and some organics.
- GAC (Granular Activated Carbon) has a micro-porous structure with an extensive surface area to provide high levels of adsorption. It is primarily used to remove oil and grease and organics such as PAHs and phthalates.

	PHOSPHOSORB	CSF	ZPG	PERLITE
Sediments	✓	✓	✓	✓
Oil and Grease	✓	✓	✓	✓
Soluble Metals	✓	✓	✓	
Organics		✓	✓	
Nutrients	✓	✓	✓	
Total Phosphorus	✓			

Note: Indicated media are most effective for associated pollutant type. Other media may treat pollutants, but to a lesser degree.

ZPG™ media is a proprietary blend of zeolite, perlite, and GAC, and is also available.

Cartridge Options

Flexibility to reduce size and costs ...

Every site is different, and one size does not fit all. Multiple cartridge heights give you design flexibility to design the StormFilter specifically for your site and reduce the cost of the system for the owner.

- 27" cartridge – Capitalizing on sites with at least 3.05 feet of available driving head, media surface area is maximized to allow the greatest treatment rate per cartridge; best for sites with footprint constraints
- 18" cartridge - The original StormFilter cartridge size provides a middle ground and operates with 2.3 feet of driving head
- Low Drop – Provides filtration treatment with only 1.8 feet of headloss; best for sites with limited by hydraulic constraints

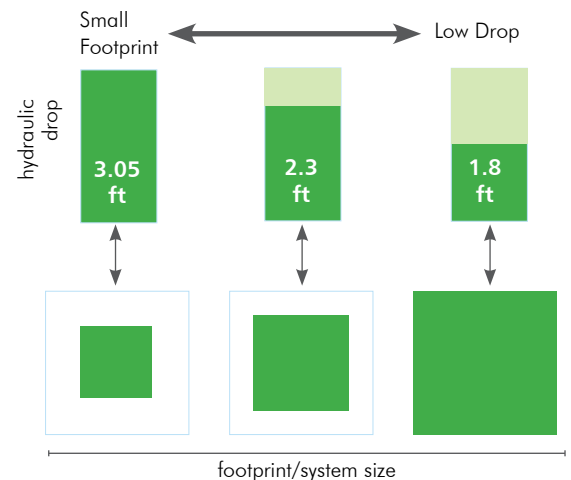

CARTRIDGE FLOW RATES			
Cartridge Height	2 gpm/ft ²	1.67* gpm/ft ²	1 gpm/ft ²
12" LD	10 gpm	8.35 gpm	5 gpm
18"	15 gpm	12.53 gpm	7.5 gpm
27"	22.5 gpm	18.79 gpm	11.25 gpm

MASS LOAD CAPACITY			
Cartridge Height	2 gpm/ft ²	1.67* gpm/ft ²	1 gpm/ft ²
12" LD	15 lbs	18 lbs	24 lbs
18"	22.5 lbs	27 lbs	36 lbs
27"	33.8 lbs	40.45 lbs	54 lbs

* For use with Phosphosorb media as per WA DOE GULD approval.

* For use with Phosphosorb media as per WA DOE GULD approval.

Configurations

Flexibility to accommodate flows, project footprints, and hydraulics ...

The structures that house the filter cartridges can be constructed in a variety of ways to accommodate a wide range of flows, project footprints, and variable hydraulic conditions. Standard configurations include catch basin, manhole, vault, curb inlet, and linear grate.

- **The Peak Diversion StormFilter** provides treatment and high flow bypass in one precast vault, eliminating the need for an external bypass or junction structures.
- **The Volume StormFilter** is designed to meet volume-based treatment regulations and can be combined with upstream storage to treat and drawdown the water quality volume within the required drain down time.
- **The Cast-in-Place StormFilter** structures allow the highest degree of flexibility and are available for installations within buildings or other areas where precast structures cannot be accommodated. On-site Contractor assistance is provided to ensure the finished product meets Contech's standards for fit and function.



Select StormFilter Approvals

The StormFilter has been verified by some of the most stringent stormwater technology evaluation organizations in North America, including:

- Washington State Department of Ecology (TAPE)
GULD – Basic, Phosphorus
- New Jersey Department of Environmental Protection (NJ DEP)
- Canada ISO 14034 Environmental Management – Environmental Technology Verified (ETV)
- North Carolina Department of Environmental Quality (NC DEQ)
- Maryland Department of the Environment (MD DOE)
- Texas Commission on Environmental Quality (TCEQ)
- Virginia Department of Environmental Quality (VA DEQ)
- Maine Department of Environmental Protection (ME DEP)
- St. Louis Metropolitan Sewer District

StormFilter Maintenance



APPLICATION TIPS

- Clogging is a major factor in the failure of filter systems. Look for systems that offer mechanisms that prevent clogging, extend service life, and reduce life-cycle cost.
- A compact design reduces construction, installation, and life-cycle cost, so look for systems that offer the most flexibility in design and construction.
- All media filters will eventually need to be replaced. Look for filters that have lightweight cartridges and provide easy access for maintenance.



An easy-to-access treatment system can make all the difference in maintenance expenses.

Every manufactured filtration device will eventually need routine maintenance. The question is how often and how much it will cost. Proper evaluation of long-term maintenance costs should be a consideration when selecting a manufactured treatment device. The StormFilter has been optimized to reduce long-term maintenance costs with proven, repeatable performance in the laboratory and in the field.

- **Reduce Life Cycle Costs** - StormFilter has been designed for predictable maintenance intervals ranging from 1 to 5 years, resulting in fewer maintenance events and reduced life-cycle costs compared to other filtration devices.

- **Easy to maintain** - All StormFilter structures provide access for inspection, media replacement, and washing of the structure. Visual indicators for maintenance are observable from the surface.
- **Cartridge replacement program** provides refurbished cartridges that are shipped to your site ready to install. Contech arranges for empty cartridges to be picked up and shipped back, reducing cartridge costs and environmental impact.
- **Maintenance support** - Contech has created a network of Certified Maintenance Providers to provide StormFilter maintenance at the lowest possible cost.

A partner you can rely on



STORMWATER
SOLUTIONS



PIPE
SOLUTIONS



STRUCTURES
SOLUTIONS

Few companies offer the wide range of high-quality stormwater resources you can find with us — state-of-the-art products, decades of expertise, and all the maintenance support you need to operate your system cost-effectively.

THE CONTECH WAY

Contech® Engineered Solutions provides innovative, cost-effective site solutions to engineers, contractors, and developers on projects across North America. Our portfolio includes bridges, drainage, erosion control, retaining wall, sanitary sewer and stormwater management products.

TAKE THE NEXT STEP

For more information: www.ContechES.com

NOTHING IN THIS CATALOG SHOULD BE CONSTRUED AS A WARRANTY. APPLICATIONS SUGGESTED HEREIN ARE DESCRIBED ONLY TO HELP READERS MAKE THEIR OWN EVALUATIONS AND DECISIONS, AND ARE NEITHER GUARANTEES NOR WARRANTIES OF SUITABILITY FOR ANY APPLICATION. CONTECH MAKES NO WARRANTY WHATSOEVER, EXPRESS OR IMPLIED, RELATED TO THE APPLICATIONS, MATERIALS, COATINGS, OR PRODUCTS DISCUSSED HEREIN. ALL IMPLIED WARRANTIES OF MERCHANTABILITY AND ALL IMPLIED WARRANTIES OF FITNESS FOR ANY PARTICULAR PURPOSE ARE DISCLAIMED BY CONTECH. SEE CONTECH'S CONDITIONS OF SALE (AVAILABLE AT WWW.CONTECHES.COM/COS) FOR MORE INFORMATION.

CONTECH[®]
ENGINEERED SOLUTIONS

Get social with us:



800-338-1122 | www.ContechES.com